

## HYDRONIC M-II

Technical description, installation,  
operation and maintenance instructions.

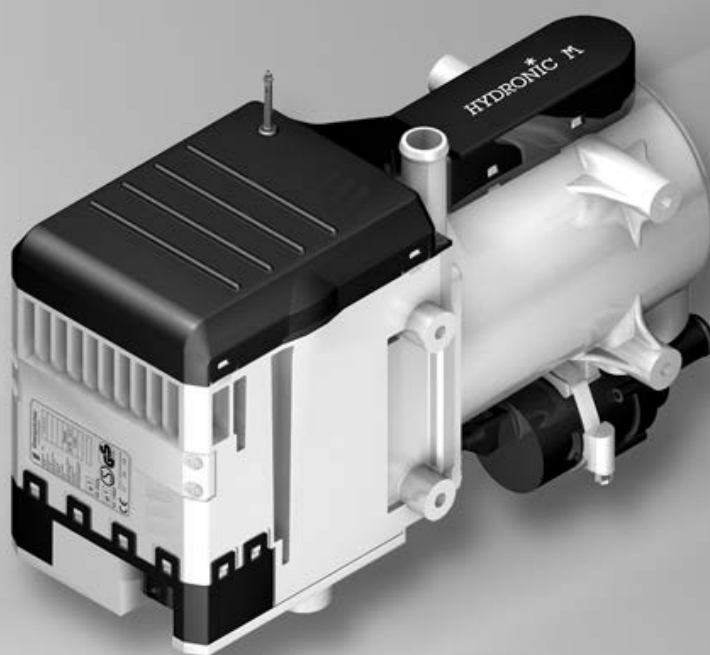

Heater	Order no.	Heater	Order no.
Hydronic M8 Biodiesel	12 V 25 2470 05 00 00	Hydronic M12	12 V 25 2472 05 00 00
	24 V 25 2471 05 00 00		24 V 25 2473 05 00 00
Hydronic M10	12 V 25 2434 05 00 00		
	24 V 25 2435 05 00 00		

**Water heater for diesel,  
operating independently of the engine.**

# 1 Introduction

## Contents

Chapter	Title	Contents
1	<b>Introduction</b>	<ul style="list-style-type: none"> <li>• Contents..... 2</li> <li>• Concept of this manual..... 3</li> <li>• Special text structure, presentation and picture symbols..... 4</li> <li>• Important information before starting work..... 4</li> <li>• Statutory regulations..... 5, 6</li> <li>• Safety instructions for installation and operation..... 7</li> <li>• Accident prevention ..... 7</li> </ul>
2	<b>Product information</b>	<ul style="list-style-type: none"> <li>• Scope of supply ..... 8, 9</li> <li>• Technical data..... 10 – 12</li> <li>• Main dimensions..... 13</li> </ul>
3	<b>Installation</b>	<ul style="list-style-type: none"> <li>• Installation location ..... 14</li> <li>• Installing the 24 V heater in a vehicle for the transport of dangerous goods as per ADR..... 14</li> <li>• Possible installation positions..... 15</li> <li>• Mounting and fastening ..... 15</li> <li>• Nameplate..... 16</li> <li>• Connection to the cooling water circuit ..... 17 – 20</li> <li>• Exhaust system ..... 21</li> <li>• Combustion air system ..... 22</li> <li>• Fuel supply ..... 23 – 27</li> </ul>
4	<b>Operation and function</b>	<ul style="list-style-type: none"> <li>• Operating instructions ..... 28</li> <li>• Initial commissioning..... 28</li> <li>• Important information for operation..... 28</li> <li>• Description of functions ..... 28</li> <li>• Control and safety devices / EMERGENCY OFF ..... 29</li> </ul>
5	<b>Electrical system</b>	<ul style="list-style-type: none"> <li>• Heater wiring ..... 30</li> <li>• Parts list for circuit diagram, heater and cable harness – 12 Volt / 24 Volt / ADR..... 31</li> <li>• Circuit diagrams..... 32 – 39</li> </ul>
6	<b>Troubleshooting Maintenance Service</b>	<ul style="list-style-type: none"> <li>• In case of faults, please check the following points ..... 40</li> <li>• Troubleshooting ..... 40</li> <li>• Maintenance instructions ..... 40</li> <li>• Service ..... 40</li> </ul>
7	<b>Environment</b>	<ul style="list-style-type: none"> <li>• Certification ..... 41</li> <li>• Disposal ..... 41</li> <li>• EU Declaration of Conformity..... 41</li> </ul>
8	<b>List</b>	<ul style="list-style-type: none"> <li>• List of abbreviations..... 42</li> </ul>



# 1 Introduction

---

## Concept of this manual

This manual aims to support the service company installing the heater and to provide the user with all important information about the heater.

The manual has been divided into 8 chapters to make it easier to find the corresponding information quickly.

### 1 Introduction

Here you will find important introductory information about installation of the heater and about the structure of the manual.

### 2 Product information

Here you will find information about the scope of supply, the technical data and the dimensions of the heater.

### 3 Installation

Here you will find important information and instructions referring to installation of the heater.

### 4 Operation and function

Here you will find information about the operation and function of the heater.

### 5 Electric system

Here you will find information about the electronic system and electronic components of the heater.

### 6 Troubleshooting / maintenance / service

Here you will find information on possible faults, maintenance and technical support.

### 7 Environment

Here you will find information about certification and disposal of the heater together with the EU Declaration of Conformity.

### 8 List

Here you will find the list of abbreviations.

# 1 Introduction

## Special text structure, presentation and picture symbols

This manual uses special text structures and picture symbols to emphasise different contents. Please refer to the examples below for the corresponding meanings and associated actions.

### Special structure and presentations

A dot (•) indicates a list which is started by a heading. If an indented dash (–) follows a dot, this list is subordinate to the dot.

### Picture symbols



#### Regulation!

This picture symbol with the remark “Regulation” refers to a statutory regulation. Failure to comply with this regulation results in expiry of the type permit for the heater and preclusion of any guarantee and liability claims on Eberspächer Climate Control Systems GmbH & Co. KG.



#### Danger!

This picture symbol with the remark “Danger!” refers to the risk of a fatal danger to life and limb. Under certain circumstances, failure to comply with these instructions can result in severe or life-threatening injuries.



#### Caution!

This picture symbol with the remark “Caution!” refers to a dangerous situation for a person and/or the product. Failure to comply with these instructions can result in injuries to people and / or damage to machinery.

#### Please note!

These remarks contain application recommendations and useful tips for installation of the heater.

## Important information before starting work

### Range of application of the heater

The water heater operating independently of an engine is intended for installation in the following vehicles, depending on its heating output:

- Vehicles of all kinds
- Construction machinery
- Agricultural machinery
- Boats, ships and yachts

#### Please note!

- Installation of the heater is permitted in vehicles used for the transport of dangerous goods as per ADR.
- The heater is not approved for installation in vehicle compartments used by persons (more than 8 passenger spaces) in Class M<sub>2</sub> and M<sub>3</sub> vehicles (vehicles for the transport of passengers / commercial buses).
- The heater is not approved for installation in the driver or passenger compartments of Class M<sub>1</sub> vehicles (vehicles for the transport of passengers / cars) and Class N vehicles (vehicles for the transport of goods).

On account of its functional purpose, the heater is **not** permitted for the following applications:

- Long-term continuous operation, e.g. for pre-heating and heating of:
  - Residential rooms
  - Garages
  - Work huts, weekend homes and hunting huts
  - Houseboats, etc.



#### Caution!

#### Safety instructions for application and proper purpose

The heater must only be used and operated for the range of application stated by the manufacturer in compliance with the “Operating instructions” included with every heater.



# 1 Introduction

## Statutory regulations

The Federal Motor Transport Authority has issued an “EC type approval”, “EMC type-approval” and the approval for a component according to ECE R122 and ECE-R10 for the heater for installation in motor vehicles with the following official type-approval marks, noted on the heater name plate.

Heater type:	ECE type approval mark:
Hydronic II	 122 R – 000215 10 R – 045075

### Regulations!

**Excerpt from ECE regulation No. 122 of the European Parliament and the Council**

#### General regulations

##### • Operating state display

- A clearly visible operating display in the user's field of vision must indicate when the heater is switched on and off.

#### Regulations concerning installation in the vehicle

##### • Scope

- Subject to differing stipulations in the following section, combustion heaters must be installed according to the regulations 5.3 of ECE-R122.
- It is assumed that Class O vehicles with heaters for liquid fuel conform to the regulations 5.3 of ECE-R122.

##### • Position of the heater

- Parts of the structure and other components near the heater must be protected from excessive heat exposure and possible fuel or oil contamination.
- The heater must not pose a fire hazard even when it overheats. This requirement is deemed to be fulfilled if adequate clearance is ensured for all parts during installation, sufficient ventilation is provided and fireproof materials or heat shields are used.
- The heater must not be mounted in the passenger compartment of vehicles in class M<sub>2</sub> and M<sub>3</sub>. However, a heater in a hermetically sealed enclosure which also complies with the aforementioned conditions may be used.
- The factory nameplate or duplicate of it must be affixed so that it can still be easily read when the heater is installed in the vehicle.
- All appropriate precautions must be taken when arranging the heater to minimise the risk of injuries to persons or damage to other property.

##### • Fuel supply

- The fuel intake connection must not be located in the passenger compartment and must be sealed with a properly closing lid to prevent any fuel leaks.
- In heaters for liquid fuel where the heater fuel is separate from the vehicle fuel, the type of fuel and intake connection must be clearly identified.
- A warning sign is to be fixed to the intake connection indicating that the heater must be switched off before refuelling.

##### • Exhaust system

- The exhaust outlet must be arranged so as to prevent any penetration of exhaust fumes into the vehicle interior through the ventilation system, warm air intakes or open windows.

##### • Combustion air intake

- The air for the heater's combustion chamber must not be sucked in from the vehicle's passenger compartment.
- The air intake must be arranged or protected in such a way that it cannot be blocked by other objects.

##### • Automatic control of the heating system

- If the engine fails, the heating system must be automatically switched off and the fuel supply stopped within 5 seconds. The heater may remain in operation if a manual device has already been activated.

#### **Please note!**

The heater is **not** approved for installation in the driver's cab or passenger compartment of Class M<sub>1</sub> vehicles (vehicles for passenger transport / cars) and N vehicles (vehicles for the transport of goods).

# 1 Introduction

## Statutory regulations

### § Regulations

#### Additional regulations for certain vehicles named in Directive 94/55/EC of the ADR Agreement

##### Scope

This annex applies to vehicles to which the special provisions of Directive 94/55/EC of the ADR Agreement for combustion heaters and their installation apply.

##### Definition of terms

The vehicle designations "EX / II", "EX / III", "AT", "FL" and "OX" according to Chapter 9.1 of the ADR Agreement Directive are used for the purposes of this annex.

##### Technical regulations

#### General provisions (EX / II, EX / III, AT, FL and OX vehicles)

##### Avoid heating and ignition

The combustion heaters and their exhaust gas routing shall be designed, located, protected or covered so as to prevent any unacceptable risk of heating or ignition of the load. This requirement shall be considered as fulfilled if the fuel tank and the exhaust system of the appliance conform to provisions in 3.1.1.1 and 3.1.1.2. Compliance with these regulations shall be checked in the complete vehicle.

##### Fuel tanks

Fuel tanks for supplying the heater shall conform to the following regulations:

- In the event of any leakage, the fuel shall drain to the ground without coming into contact with hot parts of the vehicle or the load;
- fuel tanks containing petrol shall be equipped with an effective flame trap at the filler opening or with a closure enabling the opening to be kept hermetically sealed.

##### Exhaust system and exhaust pipe layout

The exhaust system as well as the exhaust pipes shall laid out or protected to avoid any danger to the load through heating or ignition. Parts of the exhaust system situated directly below the fuel tank (diesel) shall have a clearance of at least 100 mm or be protected by a thermal shield.

##### Switching on the combustion heater

The combustion heater may only be switched on manually. Automatic switching on via a programmable switch is not permitted.

##### EX / II and EX / III vehicles

Combustion heaters for gaseous fuels are not permitted.

##### FL vehicles

Combustion heaters must be able to be taken out of service/disabled at least by the methods described in the following:

- a) Switching off manually in the driver's cabin
- b) Switching off the vehicle's engine; in this case the heater may be manually switched back on by the vehicle driver;
- c) Starting up of a feed pump installed in the vehicle for the dangerous goods carried.

##### Combustion heater after-run

After-running of the switched off combustion heater is permitted. In the cases named in the „FL vehicles“ paragraph under letters b) and c) the supply of combustion air must be interrupted by suitable means after a maximum after-run period of 40 seconds. Only combustion heaters whose heat exchangers are verifiably not damaged by the reduced after-run period of 40 seconds beyond their usual use period may be used.

#### Please note!

- Compliance with the statutory regulations, the additional regulations and safety instructions is prerequisite for guarantee and liability claims. Failure to comply with the statutory regulations and safety instructions and incorrect repairs even when using original spare parts make the guarantee null and void and preclude any liability for Eberspächer Climate Control Systems GmbH & Co. KG.
- Subsequent installation of this heater must comply with these installation instructions.
- The statutory regulations are binding and must also be observed in countries which do not have any special regulations.
- When the heater is to be installed in vehicles not subject to the German Ordinance for the Registration of Motor Vehicles (StVZO), for example ships, the specially valid regulations and installation instructions for these special applications must be observed.
- Installation of the heater in special vehicles must comply with the regulations applying to such vehicles.
- Other installation requirements are contained in the corresponding sections of this manual.



# 1 Introduction

## Safety instructions for installation and operation



### Danger!

#### Risk of injury, fire and poisoning

- Disconnect the vehicle battery before starting any kind of work.
- Before working on the heater, switch the heater off and let all hot components cool down.
- The heater must not be operated in enclosed rooms, e.g. in the garage or multi-storey car park.
- Do **not** operate the heater anywhere where there are readily flammable materials (e.g. dry grass, leaves, paper, etc.) in the area of the exhaust system or where ignitable fumes and dust can form, e.g. near a
  - fuel depot
  - coal depot
  - wood depot
  - grain depots, etc.



### Caution!

#### Safety instructions for installation and operation

- The heater must only be installed by a JE partner authorised by the manufacturer according to the instructions in this manual and possibly according to special installation recommendations; the same applies to any repairs to be carried out in the case of repairs or guarantee claims.
- Repairs by non-authorised third-parties or with not original spare parts are dangerous and therefore not allowed. They result in expiry of the type permit of the heater; consequently, when installed in motor vehicles they can cause expiry of the vehicle operating licence.
- The following measures are not allowed:
  - Changes to components relevant to the heater.
  - Use of third-party components not approved by Eberspächer Climate Control Systems GmbH & Co. KG.
  - Nonconformities in installation or operation from the statutory regulations, safety instructions or specifications relevant to safe operation as stated in the installation instructions and operating instructions. This applies in particular to the electrical wiring, fuel supply, combustion air system and exhaust system.
- Only original accessories and original spare parts must be used during installation or repairs.
- Only the controls approved by Eberspächer may be used to operate the heater. The use of other controls can result in malfunctions.
- Before the heater is installed again in another vehicle, rinse the heater parts carrying water with clear water.
- When carrying out electric welding on the vehicle, the plus pole cable at the battery should be disconnected and placed at ground to protect the controller.
- The heater must be switched off when refuelling.
- When the heater is mounted in a safety housing etc., the installation compartment of the heater is not a stowage compartment and must be kept clear. In particular fuel canisters, oil cans, spray cans, gas cartridges, fire extinguishers, cleaning rags, items of clothing, paper etc. must not be stored or transported on or next to the heater.
- Defect fuses must only be replaced by fuses with the prescribed rating.
- If fuel leaks from the heater fuel system, arrange for the damage to be repaired immediately by a JE service partner.
- When topping up the coolant, only use the coolant permitted by the vehicle manufacturer, see the vehicle operating manual. Any blending with unpermitted coolant can cause damage to the engine and heater.
- After-running of the heater must not be interrupted prematurely e.g. by pressing the battery disconnecting switch, apart from in the case of an emergency stop.

#### Please note!

Following installation, attach the “Switch off heater before refuelling!” sticker near the tank filler neck.

## Accident prevention

General accident prevention regulations and the corresponding workshop and operation safety instructions are to be observed.



## 2 Product information

### Scope of supply

Quantity / Designation	Order number
1 Hydronic M8 Biodiesel	
12 Volt	25 2470 05 00 00
24 Volt	25 2471 05 00 00
1 Hydronic M10	
12 Volt	25 2434 05 00 00
24 Volt	25 2435 05 00 00
1 Hydronic M12	
12 Volt	25 2472 05 00 00
24 Volt	25 2473 05 00 00
To be ordered separately:	
1 Control unit*	–
1 Universal installation kit	25 2435 80 00 00
1 Universal installation kit if using EasyStart Timer, Remote, Remote+ or Select	25 2435 81 00 00

\* For details of control units, please refer to the price list or product information.

#### Please note!

Please refer to the production information if any other parts are required for the installation.

### Parts list for the „Scope of supply“ figure on page 9

#### Hydronic M8 Biodiesel heater scope of supply

##### Picture-No. Designation

1	Heater
2	Metering pump
3	Relay 12 V / Relay 24 V
21	Tube, Ø 6 x 1. length 6 m
22	Transition piece Ø 3.5 / 5, (2 x)
–	Hose clamp Ø 10, (4 x)

#### Hydronic M10 / M12 heater scope of supply

##### Picture-No. Designation

1	Heater
2	Metering pump
3	Relay 12 V / Relay 24 V

#### Universal installation kit scope of supply

##### Picture-No. Designation

4	Exhaust silencer
5	Cable tree, heater
6	Bracket, heater
7	Flexible exhaust pipe
8	Cable ties (1 set)
9	Pipe, Ø 6 x 1, length 1,5 m
10	Hose, Ø 5 x 3, length 0,5 m
11	Pipe, Ø 4 x 1, length 6 m
12	Hose, Ø 3,5 x 3, length 5 cm (2 No.)
13	Intake silencer for combustion air
14	Water hose
15	Bracket
16	Lead harness, metering pump
17	Lead harness, blower
18	Bracket, metering pump
19	Bracket
–	Small parts

#### Cable harnesses

A	„Controls“ lead harness
B	„Blower control“ lead harness
C	Positive cable
D	Negative cable
E	Connection, blower relay positive supply cable at the fuse holder
F	Connection at blower relay, terminal 85 (1-pole, brown)
G	Connection at blower relay, terminal 86 (1-pole, red/yellow)
H	Metering pump connection
I	ADR feedback





## 2 Product information

### Scope of supply

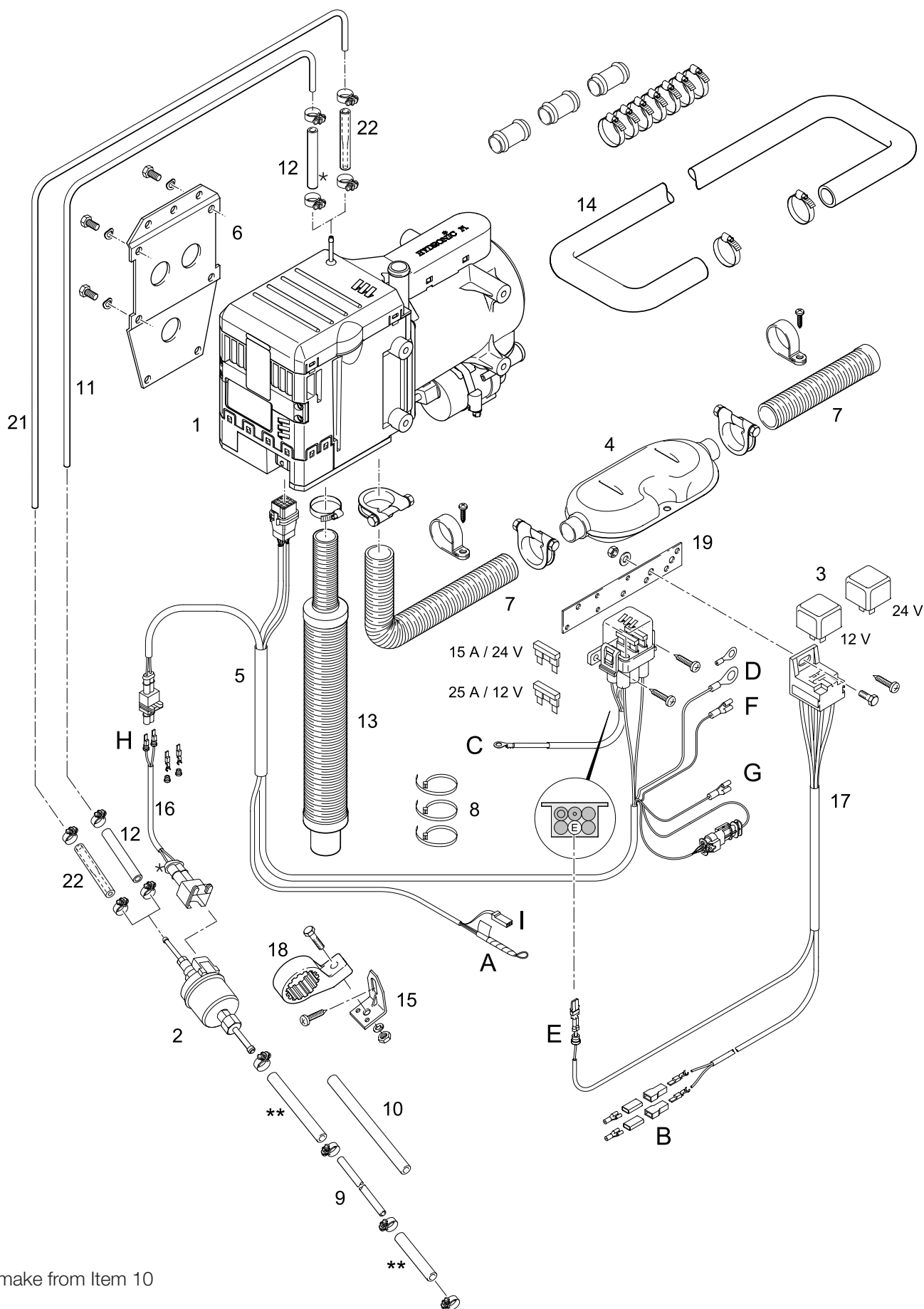

## 2 Product information

### Technical data

Heater type	<b>Hydronic M-II</b>			
Heater	Hydronic M8 Biodiesel			
Version	D 8 W			
Heating medium	Mixture of water and antifreeze (Proportion of antifreeze at least 10 % up to 50 % maximum)			
Control of the heat flow	Power	Large	Medium	Small
Heat flow (watt) Figures for operation with diesel fuel. If operated with FAME the heat flow can reduce by up to 15 %.	8000	5000	3500	1500
Fuel consumption (l/h)	0.90	0.65	0.40	0.18
Electrical power (watt)	in operation		55	46
	at start – after 25 Sek.		200	
	in the control phase “OFF”		32	
Rated voltage	12 Volt		24 Volt	
Operating range	10 Volt		20 Volt	
	15 Volt		30 Volt	
<ul style="list-style-type: none"> <li>• Lower voltage limit: An undervoltage protection in the controller switches the heater off on reaching the voltage limit.</li> <li>• Upper voltage limit: An overvoltage protection in the controller switches the heater off on reaching the voltage limit.</li> </ul>				
Tolerable operating pressure	up to 2 bar overpressure			
Flow rate of the water pump at 0.14 bar	1400 l/h			
Minimum water flow rate of the heater	500 l/h			
Fuel – see also “Fuel quality diesel heaters” page 27	Commercially available diesel (DIN EN 590) FAME – for diesel engines according to DIN EN 14 214			
Tolerable operating temperature	Operation		Not running	
	Heater / Control box	Diesel	-40 °C to +80 °C	-40 °C to +85 °C
		FAME	-8 °C to +80 °C	-40 °C to +85 °C
	Metering pump	Diesel	-40 °C to +50 °C	-40 °C to +85 °C
FAME		-8 °C to +50 °C	-40 °C to +85 °C	
Interference suppression class	interference suppression class 5 to DIN EN 55 025			
Weight with controller and water pump, without metering pump	approx. 6.2 kg			



#### Caution!

#### Safety instructions for technical data

Failure to comply with the technical data can result in malfunctions.

#### Please note!

Provided no limit values are given, the technical data listed is subject to the tolerances usually applicable to heaters of  $\pm 10\%$  for nominal voltage, ambient temperature 20 °C and reference altitude Esslingen.



## 2 Product information

### Technical data

Heater type	<b>Hydronic M-II</b>			
Heater	Hydronic M10			
Version	D 10 W			
Heating medium	Mixture of water and antifreeze (Proportion of antifreeze at least 10 % up to 50 % maximum)			
Control of the heat flow	Power	Large	Medium	Small
Heat flow (watt)	9500	8000	3500	1500
Fuel consumption (l/h)	1.2	0.9	0.4	0.18
Electrical power (watt)(l/ in operation	86	60	39	35
	at start – after 25 Sek. 120			
	in the control phase “OFF” 32			
Rated voltage	12 Volt		24 Volt	
Operating range • Lower voltage limit: An undervoltage protection in the controller switches the heater off on reaching the voltage limit. • Upper voltage limit: An overvoltage protection in the controller switches the heater off on reaching the voltage limit.	10 Volt		20 Volt	
	15 Volt		30 Volt	
Tolerable operating pressure	up to 2 bar overpressure			
Flow rate of the water pump at 0.14 bar	1400 l/h			
Minimum water flow rate of the heater	500 l/h			
Fuel – see also “Fuel quality diesel heaters” page 27	Commercially available diesel (DIN EN 590)			
Tolerable operating temperature	Operation		Not running	
	Heater / Control box		–40 °C to +85 °C	
	Metering pump		–40 °C to +50 °C	
Interference suppression class	interference suppression class 5 to DIN EN 55 025			
Weight with controller and water pump, without metering pump	approx. 6.2 kg			



#### Caution!

#### Safety instructions for technical data

Failure to comply with the technical data can result in malfunctions.

#### Please note!

Provided no limit values are given, the technical data listed is subject to the tolerances usually applicable to heaters of  $\pm 10\%$  for nominal voltage, ambient temperature 20 °C and reference altitude Esslingen.

## 2 Product information

### Technical data

Heater type	<b>Hydronic M-II</b>					
Heater	Hydronic M12					
Version	D 12 W					
Heating medium	Mixture of water and antifreeze (Proportion of antifreeze at least 10 % up to 50 % maximum)					
Control of the heat flow	Power	Large	Medium 1	Medium 2	Medium 3	Small
Heat flow (watt)	12000	9500	5000	3500	1500	1200
Fuel consumption (l/h)	1.5	1.2	0.65	0.40	0.18	0.15
Electrical power (watt)(l) in operation	132	86	46	39	35	34
	at start – after 25 Sek. 120					
	in the control phase "OFF" 32					
Rated voltage	12 Volt			24 Volt		
Operating range	10 Volt			20 Volt		
	15 Volt			30 Volt		
• Lower voltage limit: An undervoltage protection in the controller switches the heater off on reaching the voltage limit.						
• Upper voltage limit: An overvoltage protection in the controller switches the heater off on reaching the voltage limit.						
Tolerable operating pressure	up to 2 bar overpressure					
Flow rate of the water pump at 0.14 bar	1400 l/h					
Minimum water flow rate of the heater	500 l/h					
Fuel – see also "Fuel quality diesel heaters" page 27	Commercially available diesel (DIN EN 590)					
Tolerable operating temperature	Operation			Not running		
	Heater / Control box			Metering pump		
	-40 °C to +80 °C			-40 °C to +85 °C		
Interference suppression class	interference suppression class 5 to DIN EN 55 025					
Weight with controller and water pump, without metering pump	approx. 6.2 kg					



#### Caution!

#### Safety instructions for technical data

Failure to comply with the technical data can result in malfunctions.

#### Please note!

Provided no limit values are given, the technical data listed is subject to the tolerances usually applicable to heaters of  $\pm 10\%$  for nominal voltage, ambient temperature 20 °C and reference altitude Esslingen.



## 2 Product information

### Main dimensions

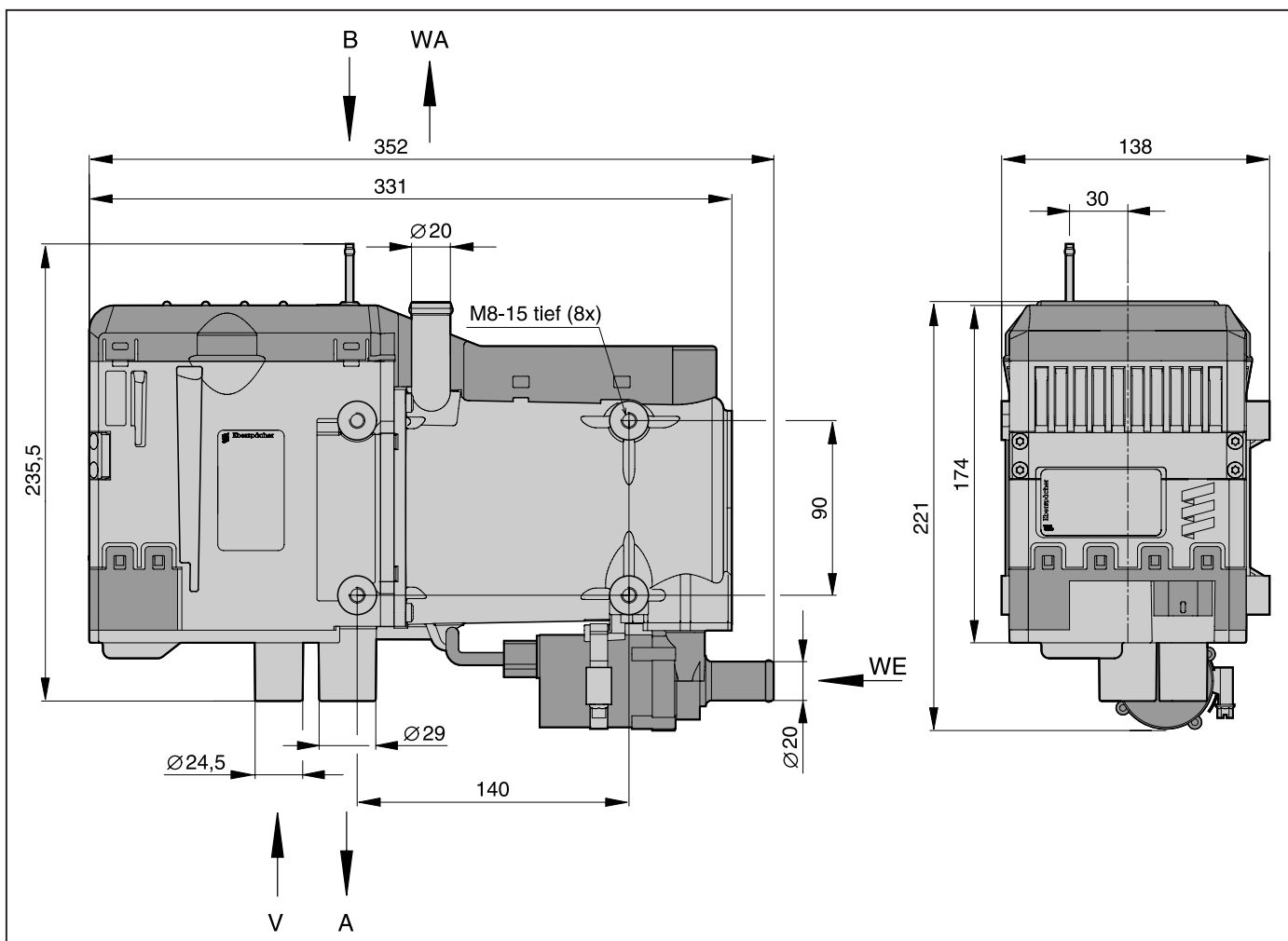

- A Exhaust
- B Fuel
- V Combustion air
- WA Water outlet
- WE Water inlet

## 3 Installation

### Installation location

The installation location for the heater is the engine compartment. The heater must be mounted below the min. cooling water level (compensation tank, cooler, vehicle heat exchanger) for automatic venting of the heat exchanger of the heater and the water pump.

#### Please note!

- In a truck, the water heater is preferably fastened underneath the driver's cab in the longitudinal beam near the vehicle engine.
- The regulations and safety instructions to be observed for this chapter are stated on page 4 – 7.
- The installation suggestions made in the installation instructions are examples. Other installation locations are possible if they correspond to the installation requirements stated in these installation instructions.
- Other installation information (e.g. for boats and ships) is available from the manufacturer on request.
- Please take note of the installation locations together with the operating and storage temperatures.

### Installation example heater in a truck

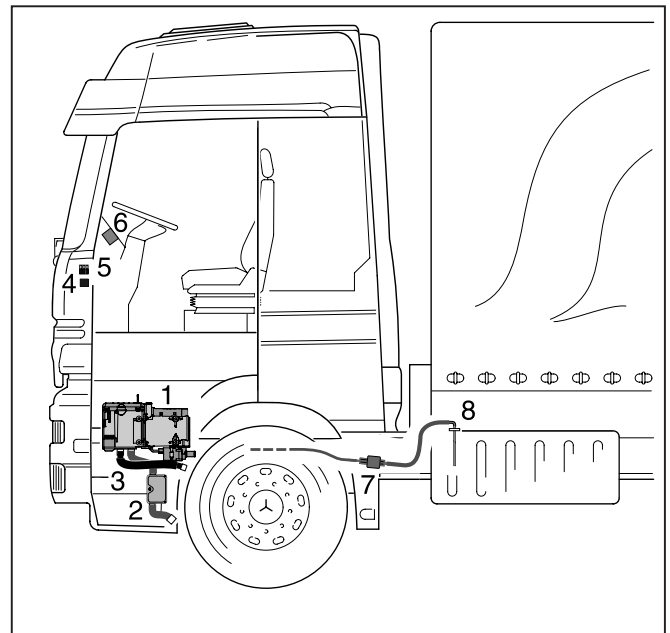

- 1 Heater
- 2 Exhaust pipe with exhaust silencer
- 3 Combustion air intake silencer
- 4 Fan relay
- 5 Fuse bracket
- 6 Controls
- 7 Metering pump
- 8 Tank connection

### Installing the 24 V heater in a vehicle for the transport of dangerous goods as per ADR

For installation of the heater in vehicles for the transport of dangerous goods, the regulations of ADR / ADR99 must be observed.

With the appropriate electrical wiring the heater fulfils the ADR regulations, see the "Additional Regulations" on Page 6, the "Control and Safety Devices" on Page 29 and the "Circuit Diagrams" on Page 34.

Detailed information about the ADR regulations is contained in leaflet no. 25 2161 95 15 80.

### 3 Installation

#### Possible installation positions

The heater should preferably be installed in the normal position, horizontal with the exhaust connection down to the bottom.

Depending on the installation conditions, the heater can also be mounted in the permitted swivel range, see diagram.

When the heater is operating, the shown normal or maximum installation positions can be varied briefly by up to +15° in all directions. Such deviations caused by the inclined position of the vehicle do not impair the heater functions in any way.

#### Normal position with permitted swivel range

- Swivel range from the normal position swivelled up to max. 85° downward – the heater's water outlet socket is horizontal. The water pump's water inlet socket must face downward.
- Swivel range from the normal position swivelled up to max. 90° to the left about the longitudinal axis – the water outlet socket is at the top of the heater and faces the left.

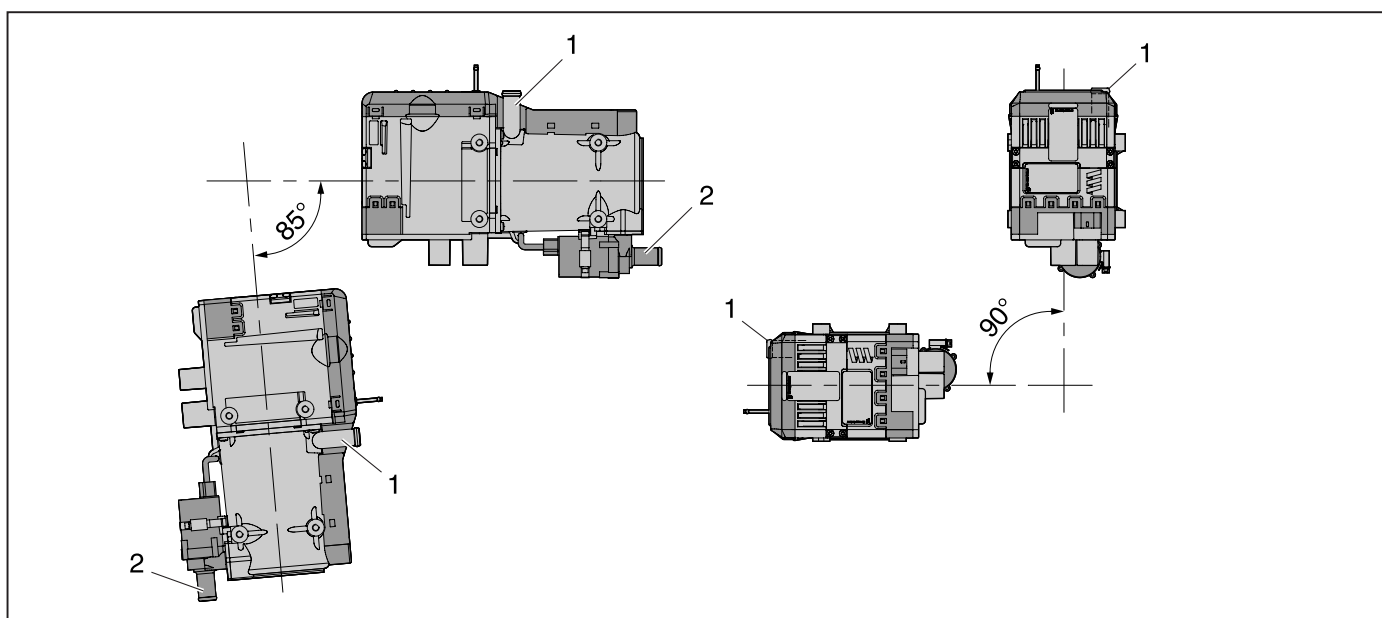

- 1 Water outlet socket, heater  
2 Water inlet socket, water pump

#### Mounting and fastening

Fix the unit holder from the installation kit to the heater using 4 hexagon screws M8 and 4 spring washers (tightening torque 12<sup>+0.5</sup> Nm).

Fix the heater and the mounted unit holder in a suitable place in the vehicle using 5 hexagon screws M8, 5 spring washers and 5 hexagon nuts M8 (tightening torque 12<sup>+0.5</sup> Nm).

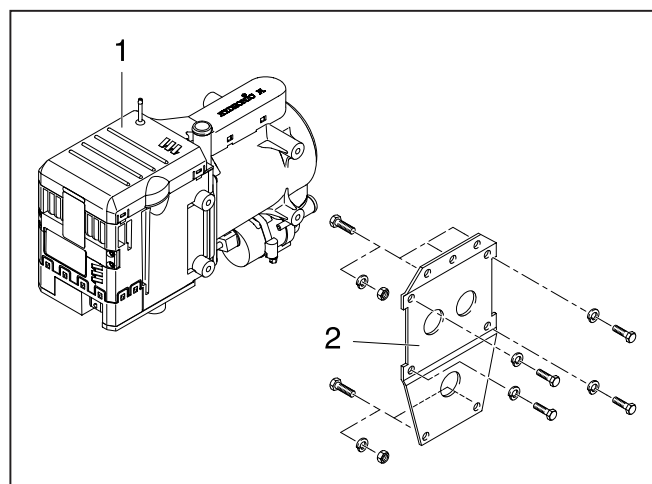

- 1 Heater  
2 Heater bracket



### 3 Installation

#### Connect and lay cable harness to heater

Connect the 12-pin connector of the cable harness to the heater.

Always route the cable harness straight out of the unit connector and fix it so that no forces can be exerted on the connector via the cable harness.

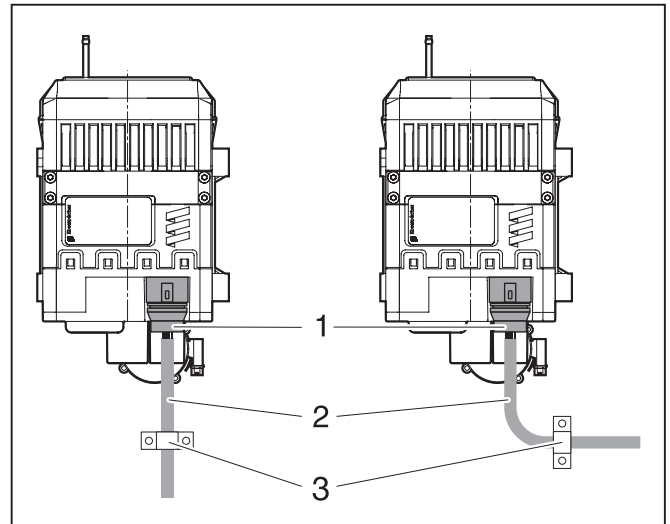

- 1 12-pin connector
- 2 Cable harness
- 3 Fixing

#### Nameplate

The nameplate is on the front and the 2<sup>nd</sup> nameplate (duplicate) is fixed to the side of the control box / fan unit.

If required, the installer can stick the duplicate nameplate in a clearly visible position elsewhere on the heater or near to the heater.

#### Please note!

The regulations and safety instructions to be observed for this chapter are stated on page 5.

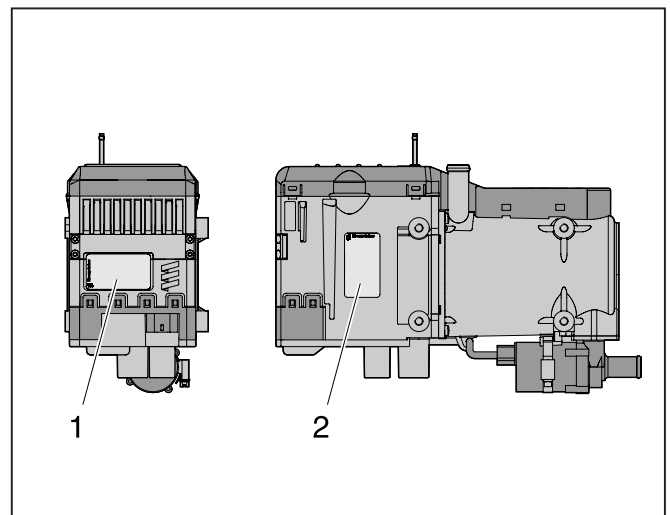

- 1 Original nameplate
- 2 2<sup>nd</sup> nameplate (dupliate)



## 3 Installation

### Connection to the cooling water circuit

The heater is connected to the cooling water circuit in the water feed pipe from the vehicle engine to the heat exchanger. There are three possible alternative installations here.

The alternatives are described on pages 16 – 18.



#### **Danger!**

#### **Risk of injuries and burns!**

It is possible for the coolant and components of the coolant circuit to get very hot.

- Parts conveying water must be routed and fastened in such a way that they pose no temperature risk to man, animals or material sensitive to temperature from radiation / direct contact.
- Before working on the coolant circuit, switch the heater off and wait until all components have cooled down completely, if necessary where safety gloves.

#### **Please note!**

- When installing the heater, please take note of the direction of flow of the coolant circuit.
- Fill the heater and water hose with anti-freeze before connecting to the cooling water circuit.
- Route the water hoses without any kinks, and in a rising position if possible.
- Where possible, the water circuit must be installed so that a cooling water temperature of approx. +60 °C is achieved after approx. 30 min.
- When routing the water pipes, observe a sufficient clearance to hot vehicle parts.
- Protect all water hoses / water pipes from chafing and from extreme temperatures.
- Secure all hose connections with hose clips. (tightening torque = 1.5 Nm)
- After the vehicle has been operating for 2 hours or travelled 100 km, tighten the hose clips again.
- The minimum water flow rate is only guaranteed if the temperature difference of the heating medium does not exceed 15 K between water inlet and water outlet during heating.
- Only overpressure valves with an opening pressure of min. 0.4 – max. 2 bar may be used in the coolant circuit.
- The cooling water must contain at least 10 % anti-freeze all year round as corrosion protection.
- During cold periods the cooling water must contain sufficient antifreeze.
- Before commissioning the heater or after changing the cooling liquid, the whole coolant circuit including heater must be vented free of bubbles according to the instructions issued by the vehicle manufacturer.
- Only top up with antifreeze approved by the vehicle manufacturer.

### 3 Installation

#### Connection to the cooling water circuit

##### Integrate the heater with non-return valve in the coolant circuit

Disconnect the water feed pipe from the vehicle engine to the vehicle heat exchanger and insert the non-return valve. Connect the heater with its water pipes to the non-return valve.

##### Advantage:

Simple installation.

##### Disadvantage:

The coolant flows through the vehicle engine constantly so that in large vehicle engines, adequate cab heating is scarcely possible.

##### Heating characteristics:

When the heater is switched on, the heat flows through the vehicle heat exchanger and the vehicle engine. Once the cooling water has reached a temperature of approx. 55 °C, depending on the selected fan setting the vehicle fan is switched on and the heat is also conveyed to the passenger compartment.

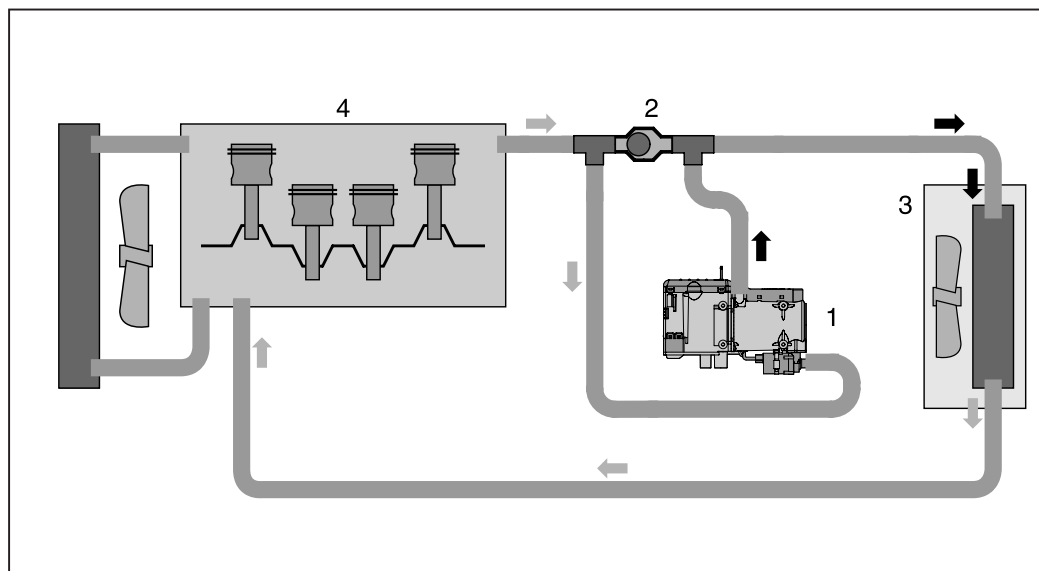

#### Please note!

Non-return valve must be ordered separately, please refer to the product information for the Order No.

### 3 Installation

#### Connection to the coolant circuit

##### Integrate the heater with non-return valve, thermostat and T-piece in the coolant circuit

Disconnect the water feed pipe from the vehicle engine to the vehicle heat exchanger and insert the non-return valve.

Disconnect the water return pipe from the heat exchanger to the vehicle engine and insert the T-piece.

Connect the heater and thermostat with water hoses to the non-return valve and T-piece as shown in the diagram.

##### Option:

In addition a solenoid can be fitted in the water circuit. When open, this bypasses the thermostat and pre-heats the engine as soon as the heater starts to work.

#### Heating characteristics

##### • Small coolant circuit: fast heating of the passenger compartment

Initially the heat produced by the heater is only conveyed to the vehicle heat exchanger up to a cooling water temperature of approx. 70 °C.

The vehicle fan switches on at approx. 55 °C.

##### • Large cooling water circuit: heating of the passenger compartment and additional engine pre-heating

If the cooling water temperature continues to increase, the thermostat slowly changes over to the large circuit (full change-over at approx. 75 °C).

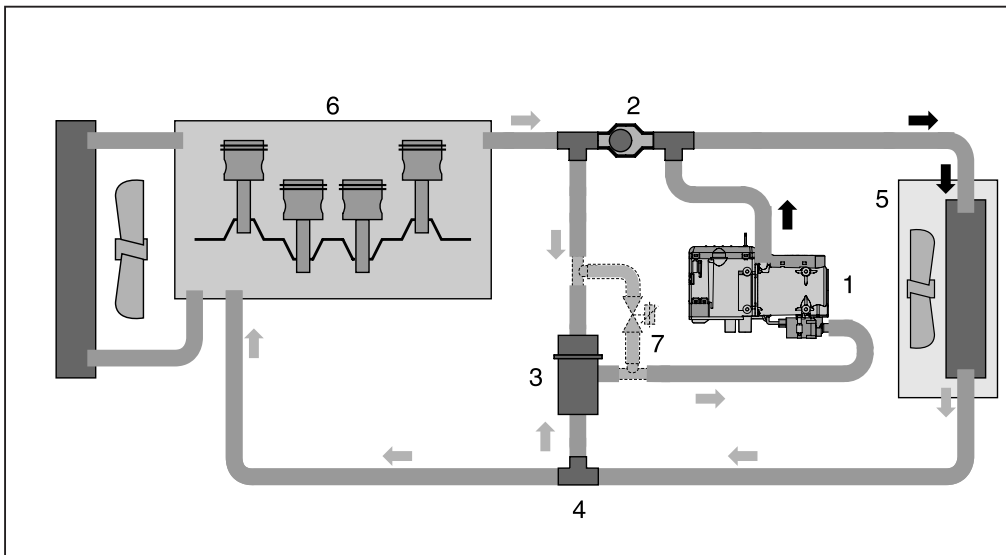

- 1 Heater
- 2 Non-return valve
- 3 Thermostat
- 4 T-piece
- 5 Heat exchanger
- 6 Vehicle engine
- 7 Solenoid (option)

#### Please note!

The thermostat, non-return valve and T-piece must be ordered separately, please refer to the product information for the Order No.

The solenoid valve has to be purchased through the trade.

#### Thermostat functions

##### Small coolant circuit

Cooling water temperature < 70 °C:

Connection no. 1: open to the heater

Connection no. 2: open to the T-piece

Connection no. 3: closed to the non-return valve

##### Large coolant circuit

Cooling water temperature > 75 °C:

Connection no. 1: open to the heater

Connection no. 2: closed to the T-piece

Connection no. 3: open to the non-return valve

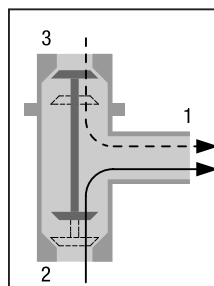

- 1 Connection to the heater
- 2 Connection to the T-piece
- 3 Connection to the non-return valve

#### Please note!

Integrate the thermostat into the water circuit with connections (1) (2) and (3) as shown in the diagram.

### 3 Installation

#### Connection to the coolant circuit

##### Integrate the heater with a solenoid in the coolant circuit

Disconnect the water flow hose from the vehicle's engine to the vehicle's heat exchanger and insert two T-pieces. Connect the T-pieces with a hose. Disconnect the water return pipe from the heat exchanger to the vehicle engine and insert the solenoid. Connect the heater and the solenoid to the T-piece with water pipes, as shown in the diagram.

##### Option:

In addition, a non-return valve with connection hoses between the two T-pieces can be inserted in the cooling water circuit. This prevents the loss of effective vehicle heating when the heater is switched off.

##### Heating characteristics

By installing the electric solenoid valve, temperature-independent choice between the small cooling water circuit (driver's cab) and large cooling water circuit (vehicle engine with driver's cab) is possible. Alternatively, a plus signal from the 12-pin connector B2, PIN B1 to relay 2.5.7 can be used to control the solenoid valve; this enables automatic changeover of the solenoid valve (see circuit diagrams page 32 and 34). Changeover to the large cooling water circuit at a cooling water temperature of 68 °C, if the temperature drops to 58 °C. Changeover to the small cooling water circuit at a cooling water temperature of 63 °C, if the temperature drops to 45 °C.

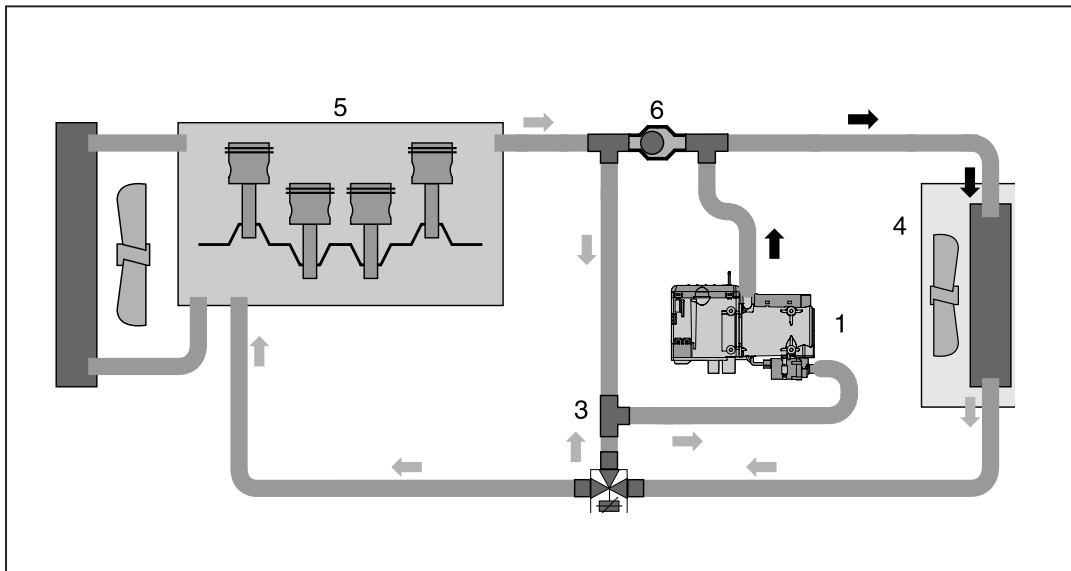

- 1 Heater
- 2 Solenoid
- 3 T-piece
- 4 Heat exchanger
- 5 Vehicle engine
- 6 Non-return valve (option)

#### Please note!

T-pieces (tees) and non-return valve must be ordered separately, please refer to the product information for the Order No.

The solenoid valve has to be purchased through the trade.



## 3 Installation

### Exhaust system

(Exhaust diagram see page 22)

#### Mounting the exhaust system

The universal installation kit includes a flexible exhaust pipe, inner Ø 30 mm, 1300 mm long and an exhaust silencer.

The exhaust silencer must be installed.

The flexible exhaust pipe can be shortened to 20 cm or lengthened to max. 1.8 m, depending on the installation conditions (See sketch on page 22).

Fasten the exhaust silencer to a suitable position in the vehicle.

Route the flexible exhaust pipe from the heater to the exhaust silencer and fasten with pipe clips.

If necessary, also fasten the flexible exhaust pipe with pipe clips at suitable positions in the vehicle.

Connect the exhaust end pipe to the exhaust silencer with an end sleeve and fasten with a pipe clip.



#### **Danger!**

#### **Risk of injuries and burns!**

Every type of combustion produces high temperatures and toxic exhaust fumes. This is the reason why the exhaust system must be installed according to these instructions.

- Do not perform any work on the exhaust system while the heater is working.
- Before working on the exhaust system, first switch the heater off and wait until all parts have cooled down completely, wear safety gloves if necessary.
- Do not inhale exhaust fumes.



#### **Caution!**

#### **Safety instructions for the exhaust system!**

- The exhaust outlet must end in the open air.
- The exhaust pipe must not protrude beyond the lateral limits of the vehicle.
- Install the exhaust pipe sloping slightly downwards. If necessary, make a drain hole approx. Ø 5 mm at the lowest point to drain off condensation.
- Important functional parts of the vehicle must not be impaired (keep sufficient clearance).
- Mount the exhaust pipe with sufficient clearance to heat-sensitive parts. Pay particular attention to fuel pipes (plastic or metal), electrical cables and brake hoses etc.!
- Exhaust pipes must be fastened safely (recommended clearance of 50 cm) to avoid damage from vibrations.
- Route the exhaust system so that the emitted fumes are not sucked in with the combustion air.
- The mouth of the exhaust pipe must not get clogged by dirt and snow.
- The mouth of the exhaust pipe must not point in the direction of travel.
- Always fasten the exhaust silencer to the vehicle.

#### **Please note!**

- Comply with the regulations and safety instructions for this chapter on page 4 – 7.
- The exhaust end pipe should be much shorter than the flexible exhaust pipe from the heater to the exhaust silencer.
- Use pipe clips to secure all connections in the exhaust system.
- To avoid contact corrosion, the clips for fixing the exhaust pipe must be made of stainless steel. Please refer to the product information for the Order No. of the stainless steel fixing clips.

### 3 Installation

#### Combustion air system

##### Mounting the combustion air system

The universal installation kit includes an intake silencer, inner Ø 25 mm for the combustion air.

The intake silencer must be installed and, for heating mode up to 1500 m asl, can be extended by up to 2 m max. using a flexible pipe (inner Ø 25 mm) and a connection pipe (outer Ø 24 mm) – not included in the scope of supply.

Fasten the intake silencer and where applicable the flexible pipe at suitable points in the vehicle using fastening clips and cable ties.

##### Please note!

- Comply with the regulations and safety instructions for this chapter on page 4 – 7.
- Extension of the intake silencer is not allowed if mainly heating mode is used at high altitudes (over 1500 m asl).
- Use pipe clips to secure all connections in the combustion air system.
- For installation in ships and boats, see marine catalogue, if necessary consult the manufacturer.



##### Caution!

##### Safety instructions for the combustion air system!

- The combustion air must be drawn from an area in which the maximum allowable temperature for the combustion air, of 45 °C, is not exceeded.
- The combustion air opening must be free at all times.
- Position the combustion air intake to be sure that exhaust fumes cannot be sucked in with the combustion air.
- The combustion air intake must not get clogged with dirt and snow.
- Install the combustion air intake system sloping slightly downwards.
- If necessary, make a drain hole approx. Ø 5 mm at the lowest point to drain off condensation.
- Avoid tight bends when laying the intake silencer and flexible pipe.

#### Allowable combustion air and exhaust pipe length

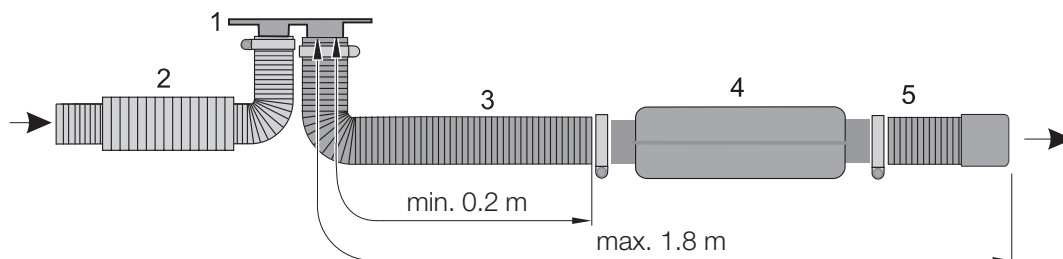

With a combustion air system consisting only of one intake silencer, heating mode is possible up to an altitude 3500 m asl (with Hydronic M10 / M12 only).

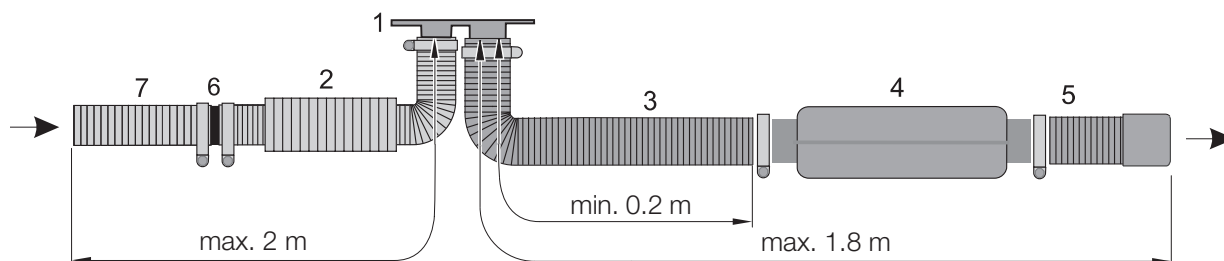

With a combustion air system consisting of one intake silencer and an extension, heating mode is possible up to an altitude of 1500 m asl (all heater models).

- |  |  |
|--|--|
| 1 Heater flange  | 4 Exhaust silencer                           |
| 2 Intake silencer, 565 mm long<br>(Order No. 20 1689 80 05 00) | 5 Flexible exhaust end pipe                  |
| 3 Flexible exhaust pipe  | 6 Connector (Order No. 25 1226 89 00 31)     |
|  | 7 Flexible pipe (Order No. 10 2114 21 00 00) |



## 3 Installation

### Fuel supply

#### Mounting the metering pump, routing the fuel pipes and mounting the fuel tank

The following safety instructions must be observed when mounting the metering pump, routing the fuel pipes and mounting the fuel tank.



#### **Danger!**

#### **Risk of fire, explosion, poisoning and injuries!**

Caution when handling fuel.

- Switch off the vehicle engine and heater before refuelling and before working on the fuel supply.
- No naked lights when handling fuel.
- Do not smoke.
- Do not inhale fuel vapours.
- Avoid any contact with the skin.



#### **Caution!**

#### **Safety instructions for routing the fuel pipes!**

- Only use a sharp knife to cut off fuel hoses and pipes. Interfaces must not be crushed and must be free of burrs.
- The fuel pipe from the metering pump to the heater should be routed at a continuous rise.
- Fuel pipes must be fastened safely to avoid any damage and / or noise production from vibrations (recommended clearance of approx. 50 cm).
- Fuel pipes must be protected from any mechanical damage.
- Route the fuel pipes so that any distortion of the vehicle, engine movements etc. cannot have any lasting effect on the service life.
- Parts carrying fuel must be protected from interfering heat.

- Never route or fasten the fuel pipes to the heater or vehicle exhaust system. When the systems cross, always ensure there is a sufficient heat clearance. If necessary, install heat deflection plates.
- Dripping or evaporating fuel must never be allowed to collect on hot parts or ignite on electric systems.
- When connecting fuel pipes with a fuel hose, always mount the fuel pipes in a butt joint to prevent any bubbles from forming.

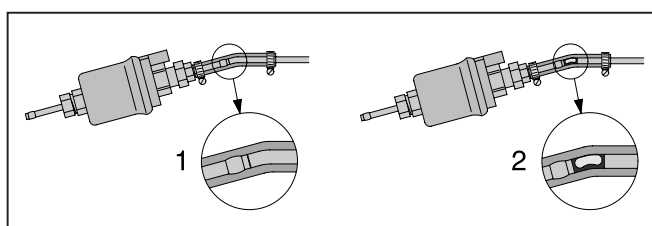

- 1 Correct connection
- 2 Incorrect connection – bubble formation

#### **Please note!**

- Deviations from the instructions stated here are not allowed.
- Failure to comply can result in malfunctions.
- When replacing the Hydronic M (Hydronic 10) with the Hydronic M-II, the metering pump must be replaced too.

#### **Safety instructions for fuel pipes and fuel tanks in buses and coaches**

- In buses and coaches, fuel pipes and fuel tanks must not be routed through the passenger compartment or driver's cab.
- Fuel tanks in buses and coaches must be positioned in such a way that the exits are not in direct danger from a possible fire.

#### **Please note!**

Comply with the regulations and safety instructions for this chapter on page 4 – 7.

### 3 Installation

#### Fuel supply

#### Fuel feed point with T-piece from the fuel supply line from the tank fitting to the vehicle engine

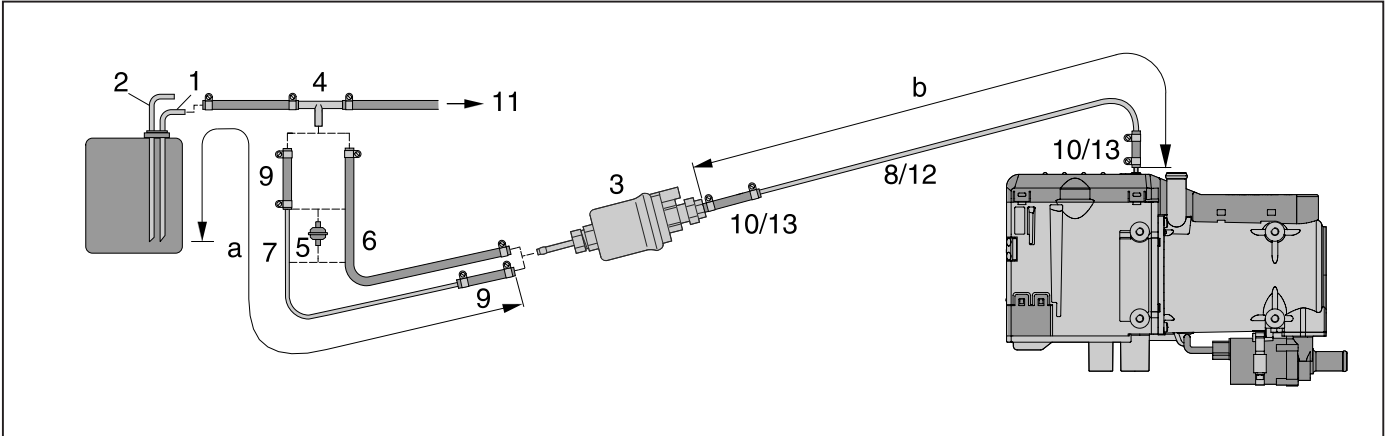

- 1 Fuel feed pipe from tank connection
- 2 Fuel return pipe to the tank connection
- 3 Metering pump
- 4 T-piece
- 5 Fuel filter
- 6 Fuel hose, 5 x 3 (di = Ø 5 mm)
- 7 Fuel pipe, 6 x 1 (di = Ø 4 mm)
- 8 Fuel pipe, 4 x 1 (di = Ø 2 mm)
- 9 Fuel hose, 5 x 3 (di = Ø 5 mm), approx. 50 mm long
- 10 Fuel hose, 3,5 x 3 (di = Ø 3,5 mm), approx. 50 mm long
- 11 To the engine, mechanical fuel or injection pump.

Required for Hydronic M8 biodiesel for operation with FAME only.

- 12 Fuel pipe blue, 6 x 1 (di = Ø 4 mm)
- 13 Transition piece 3,5 / 5

#### Possible pipe lengths

##### Intake side

a = max. 2 m

##### Pressure side

b = min. 1.5 m – max. 6 m

#### Please note!

- Insert the T-piece, Item (4), in the fuel flow line, upstream of the feed pump. T-piece is not included in the “Installation kit” scope of supply. For Order No. please refer to product information.
- Fuel filter, Item (5), is required for contaminated fuel only. Fuel filter is not included in the “installation kit” scope of supply. For Order No. please refer to product information.
- Items (12) and (13) are only included in the “Hydronic M8 Biodiesel” heater’s scope of supply.

#### Installation position of the T-piece

Use the installation positions shown in the diagram when inserting a T-piece.

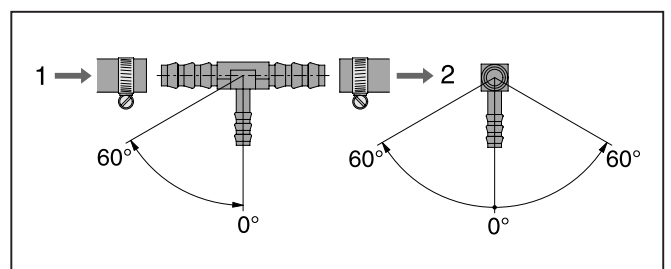

- 1 Direction of flow from the fuel tank
- 2 Direction of flow to the vehicle engine

### 3 Installation



#### Fuel supply

#### Fuel feed point with tank connection – ascending pipe, integrated in the vehicle tank

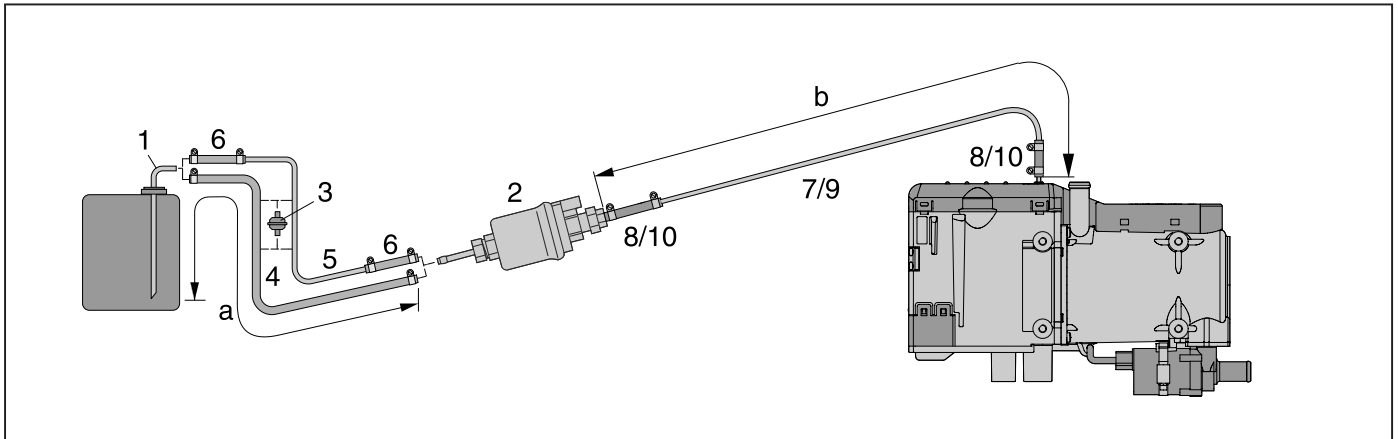

- 1 Tank connection for metal tank –  
di = Ø 4 mm, da = Ø 6 mm
- 2 Metering pump
- 3 Fuel filter
- 4 Fuel hose, 5 x 3 (di = Ø5 mm)
- 5 Fuel pipe, 6 x 1 (di = Ø 4 mm)
- 6 Fuel hose, 5 x 3 (di = Ø 5 mm), approx. 50 mm long
- 7 Fuel pipe, 4 x 1 (di = Ø 2 mm)
- 8 Fuel hose, 3,5 x 3 (di = Ø 3.5 mm), approx. 50 mm long

Required for Hydronic M8 biodiesel for operation with FAME only.

- 9 Fuel pipe blue, 6 x 1 (di = Ø 4 mm)
- 10 Transition piece 3,5 / 5

#### Possible pipe lengths

##### Intake side

a = max. 2 m

##### Pressure side

b = min. 1.5 m – max. 6 m

#### Please note!

- Item (1), tank connection for metal tank, is not included in the “installation kit” scope of supply. For Order No. please refer to product information.
- Fuel filter, Item (3), is required for contaminated fuel only. Fuel filter is not included in the “installation kit” scope of supply. For Order No. please refer to product information.
- Items (9) and (10) are only included in the “Hydronic M8 Biodiesel” heater’s scope of supply.
- When installing tank connection maintain a minimum distance of  $50 \pm 2$  mm from the end of the riser pipe and the bottom of the tank.



#### Caution!

#### Safety instructions for the fuel supply!

- The fuel must not be conveyed by gravity or overpressure in the fuel tank.
- Withdrawal of fuel after the vehicle’s fuel pump is not allowed.
- When the pressure in the fuel pipe is more than 0.2 bar or there is a non-return valve in the return pipe (in the tank), a separate tank connection must be used.
- When using a T-piece in a plastic pipe, always use support sleeves in the plastic. Connect the T-piece and the plastic pipe with corresponding fuel hoses and secure with hose clips.

### 3 Installation

#### Fuel supply

##### Installation position of the metering pump

Always mount the metering pump with the pressure side rising upwards. Every installation position over 15° is allowed, although an installation position between 15° and 35° is preferable.

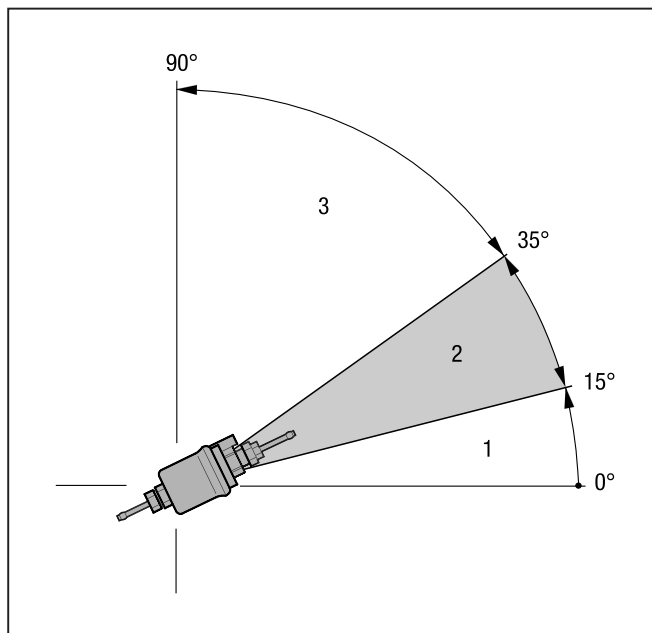

- 1 Installation position between 0° and 15° is not allowed.
- 2 Preferred installation position in range 15° to 35°.
- 3 Installation position in range 35° to 90° is allowed.

##### Possible intake and pressure height of the metering pump

Pressure height from vehicle tank to metering pump:  
a = max. 1000 mm

Intake height for non-pressurised vehicle tank:  
b = max. 750 mm

Intake height for a vehicle tank with withdrawal by negative pressure (valve with 0.03 bar in the tank lid):  
b = max. 400 mm

Pressure height from the metering pump to the heater:  
c = max. 2000 mm

**Please note!**

Check tank venting.

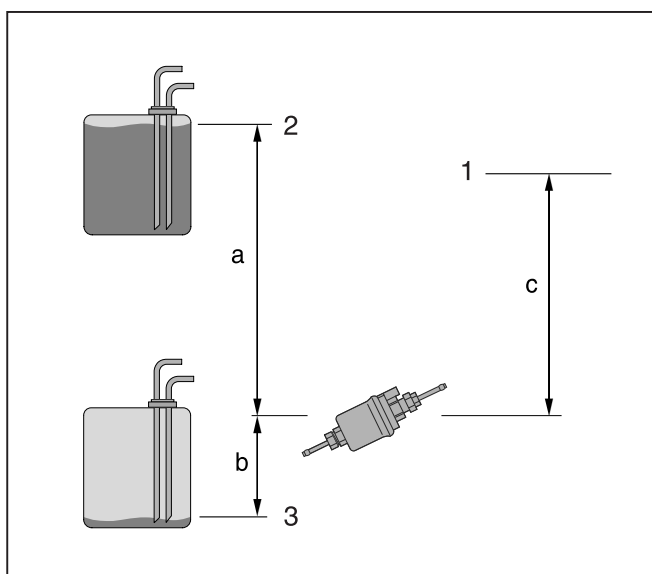

- 1 Connection to heater
- 2 Max. fuel level
- 3 Min. fuel level

**Caution!**

##### Safety instructions for installing the metering pump

- Always mount the metering pump with the pressure side rising upwards – minimum incline 15°.
- Protect the metering pump and filter from intolerable heat, do not mount near to the silencers and exhaust pipes.



## 3 Installation

### Fuel supply

#### Fuel quality

- Hydronic M8 Biodiesel, M10 and M12 heaters easily process standard diesel fuel to EN 590.

During the winter months the diesel fuel is adapted to low temperatures from 0 °C to –20 °C. Problems can therefore only arise if outdoor temperatures are extremely low – which also applies to the vehicle's engine – please refer to the vehicle manufacturer's regulations.

- In special cases and at outdoor temperatures above 0 °C the heater can also be run on heating oil EL according to DIN 51603.
- If the heater is run from a separate tank, please comply with the following rules:
  - If outdoor temperatures over 0 °C:  
Use diesel fuel according to DIN EN 590.
  - If outdoor temperatures from 0 °C to –20 °C:  
Use winter diesel fuel according to DIN EN 590.
  - If outdoor temperatures –20 °C to –40 °C:  
Use Arctic Diesel or Polar Diesel.

#### Please note!

- It is **not** permitted to add used oil!
- After refuelling with winter or cold diesel or the listed blends, the fuel pipes and the metering pump must be filled with the new fuel by letting the heater run for 15 mins!

#### Operation with biodiesel (FAME for diesel engines according to DIN EN 14 214)

##### Hydronic M8 Biodiesel

The heater is approved for operation with biodiesel up to a temperature of – 8°C (the flowability reduces at temperatures below 0 °C).

#### Please note!

- When using 100 % biodiesel, the heater should be run on diesel fuel twice a year (in the middle and at the end of a heating period) to burn off possibly accumulated biodiesel deposits. To do so, let the vehicle tank run almost empty and fill with diesel fuel without adding any biodiesel. While running on this tank filling, switch the heater on 2 to 3 times for 30 minutes at a time at the highest temperature setting.
- If constantly operated with diesel / biodiesel mixtures of up to 50 % biodiesel, intermediate operation with pure diesel fuel is not necessary.

##### Hydronic M10 / Hydronic M12

Both heaters are **not** approved for operation with biodiesel.

Up to 10 % biodiesel may be added.

## 4 Operation and function

### Operating instructions

The heater is operated by a control unit. The control unit is accompanied by detailed operating instructions which you will receive from the company installing the heater.

### Initial commissioning

The following points are to be checked by the company installing the heater during initial commissioning.

- After installation of the heater, the coolant circuit and the whole fuel supply system must be vented carefully. Comply with the instructions issued by the vehicle manufacturer.
- Open the coolant circuit before the trial run (set the temperature control to "WARM").
- During the trial run of the heater, check all water and fuel connections for leaks and firm fitting.
- If the heater shows a fault during operation, find and eliminate the cause of the fault using a diagnosis unit (Contact JE service partner).

### Important instructions for operation

#### Safety checks before the start

After a longer interval in operations (after the summer months) the fuse must be put in position and / or the heater connected up to the battery. Check that all parts fit firmly (tighten screws where necessary). Check the fuel system visually for any leaks.

#### Before switching on

Before switching on or pre-programming the heater, adjust the heating control in the vehicle to "WARM" (maximum setting) and the fan to "SLOW" (low power consumption).

In vehicles with automatic heating, adjust the heating control to "MAX" and open the heating vents before switching the ignition off.

#### Temperature drop (optional)

The control stages are reached earlier and the heater's control action is adjusted to the lower heat requirement. It is possible to lower the temperature by connecting a plus signal to the 12-pin connector B2, PIN C3, if necessary by integrating an ON-OFF switch (see circuit diagram page 32).

The switch-on temperature (55 °C) and switch-off temperature (40 °C) of the cooling water for switching on or off the vehicle fan are lowered by 10 °C.

### Heating mode at high altitudes – up to 3500 m asl

The combustion behaviour of the heater changes with increasing altitude, due to the lower air density. The heater has an automatic altitude detection device which it uses to automatically compensate for the change in air density, i.e. the combustion ratio between fuel and air is adapted to the ambient conditions by reducing the fuel quantity.

#### Please note!

- The usual switching limit for altitude detection lies between 1000 m asl and 2000 m asl and solely depends on the local climatic conditions.
- The maximum heating output of the Hydronic M10 / M12 in "Altitude Mode" is 8.5 kW.
- The Hydronic M8 Biodiesel does not have an altitude detection device. Unrestricted heating mode is possible up to 1500 m asl.
- Heaters suitable for high altitudes have "H Kit" marked on the side of the nameplate.

### Description of functions

#### Switching on

On being switched on, the switch-on check is displayed in the control unit. The heater starts, whereby the water pump and the combustion air blower start up first. The glow phase of the glow pencils begins simultaneously with distribution of the combustion air. The metering pump starts fuel feed somewhat delayed. The glow pencils are switched off if a stable flame has formed in the combustion chamber.

#### Heating mode

After starting, the heater runs with "POWER" stage until the water temperature exceeds the "POWER" / "HIGH" changeover threshold.

#### Hydronic M8 Biodiesel / M10

Then, depending on the heat requirement, the heater switches to the "HIGH – MEDIUM – LOW – OFF" stages.

#### Hydronic M12

Then, depending on the heat requirement, the heater switches to the "HIGH – MEDIUM 1 / MEDIUM 2 / MEDIUM 3 – LOW – OFF" stages.

If the heating requirement in the "LOW" stage is so small that the cooling water temperature reaches 86 °C, the heater switches from "LOW" to "OFF".

An after-run of approx. 180 seconds follows.

The water pump remains active until the controlled start. If the cooling water has cooled to approx. 72 °C, the Hydronic M8 / M10 heater starts in "MEDIUM" stage, the Hydronic M12 heater starts in "MEDIUM 1" stage. If the cooling water temperature reaches 55 °C, the vehicle fan switches on; if the temperature drops to 40 °C, the vehicle fan switches back off again.



## 4 Operation and function

### Switching off

After switching off, the heater briefly switches to “LOW” stage to reduce emissions and smoke formation. This process can take up to 40 seconds maximum if the fuel quantity is constantly reduced. Once this process has finished the heater starts the after-run for 180 seconds. During the after-run both glow plugs are switched on alternately.

#### Please note!

In independent heater mode (vehicle engine and heater are switched on), always ensure that the heater is completely switched off before entering a petrol station area.

### Control and safety devices

The heater is equipped with the following control and safety devices:

- If the heater does not ignite within 74 seconds after starting the fuel pump, the start is repeated. If the heater still does not ignite after another 65 seconds, the heater is switched off.\*  
After an unacceptable number of failed start attempts, the controller is locked.\*\*
- If the flame goes off by itself during operation, the heater is restarted. If the heater does not ignite within 74 seconds after the fuel pump has started again, the heater is switched off.\*  
After an unacceptable number of failed start attempts, the controller is locked.\*\*
- In the case of overheating (e.g. lack of water, poorly vented coolant circuit), the overheating sensor triggers, the fuel supply is interrupted and the heater switched off.\*  
Once the cause of overheating has been eliminated, the heater can be re-started by switching off and on again (on condition that the heater has cooled down again sufficiently, cooling water temperature <72 °C). After the heater has been switched off for overheating an unacceptable number of times, the controller is locked.\*\*
- If the water temperature is +50 °C or higher, the heater can also switch to control stage OFF if the water throughput rate is too low. An afterrun of approx. 180 seconds follows.
- The heater is switched off if the upper or lower voltage limit is reached.\*
- The heater does not start up if the electric cable to the metering pump is interrupted.
- If one of the two glow plugs is defective the start sequence takes place with one glow plug only.

- The speed of the fan motor is monitored continuously. If the blower motor does not start up if it is blocked, or if the speed differs by > 12.5 % from the desired speed a safety lockout (shutdown on faults) takes place after 60 sec.\*
- The water pump's function is continuously monitored.

\* This status can be remedied by briefly switching off and on again.

\*\*The control box can be unlocked with testing equipment / a control unit. For the procedure and description for testing equipment and control units, see “Installation Instructions Plus – EasyStart/Altitude Kit / Special Functions and Diagnosis”  
For details of how to cancel the lock and to read out errors, refer to the Troubleshooting and Repair instructions of the heater.

#### Please note!

Do not switch the heater off and on again more than twice.

### Forced shut-down for ADR operation

In vehicles for the transport of dangerous goods (e.g. tanker trucks), the heater must be switched off before the truck drives into a danger area (refinery, fuel service station, etc.)

Failure to comply results in the heater switching off automatically when:

- The vehicle engine is switched off.
- An additional unit is started up (e.g. auxiliary drive for unloading pump etc.).

The fan then runs on for max. 40 seconds.

#### Emergency shutdown – EMERGENCY OFF

If an emergency shutdown – EMERGENCY OFF – is necessary during operation, proceed as follows:

- Switch the heater off with the control or
- pull the fuse out or
- disconnect the heater from the battery.



## 5 Electrical system

### Heater wiring

The heater is to be connected up electrically according to the EMC directives.



#### Caution!

#### Safety instructions for wiring the heater

EMC can be affected if the heater is not connected up correctly. For this reason, comply with the following instructions:

- Ensure that the insulation of electrical cables is not damaged. Avoid: chafing, kinking, jamming or exposure to heat.
- In waterproof connectors, seal any connector chambers not in use with filler plugs to ensure they are dirt- and water-proof.
- Electrical connections and ground connections must be free of corrosion and firmly connected.
- Lubricate connections and ground connections outside the heater interior with contact grease.

#### Please note!

Comply with the following when wiring the heater and the control element:

- Electrical leads, switchgear and controllers must be arranged in the vehicle so that they can function perfectly under normal operating conditions (e.g. heat exposure, moisture etc.).
- The following cable cross sections are to be used between the battery and heater. This ensures that the max. tolerable voltage loss in the cables does not exceed 0.5 V for 12 V or 1 V for 24 V rated voltage. Cable cross sections for a cable length of:
  - up to 5 m (plus cable + minus cable) = cable cross section 4 mm<sup>2</sup>
  - from 5 to 8 m (plus cable + minus cable) = cable cross section 6 mm<sup>2</sup>
 Connection of the cables (plus cable and minus cable) to connector B2 requires a reduction in the cable cross-section to 2.5 mm<sup>2</sup>.
- If the plus cable is to be connected to the fuse box (e.g. terminal 30), the vehicle cable from the battery to the fuse box must be included in rating the overall cable length and possibly re-dimensioned if necessary.
- Insulate unused cable ends.

### Notes on rewiring the 12-pin cable harness connector

If, on replacing the Hydronic M (Hydronic 10) with the Hydronic M-II, the cable harness already installed in the vehicle is to be reused it is necessary to remove the 12-pin connector using the AMP release tool and to rewire it according to the following table (AMP Order No. 1-1579007-4).

#### 12-pin connection pin assignment

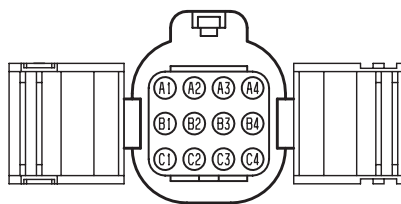

Connector is shown from the cable entry side.

Cable harness Hydronic M		Rewiring 12-pin connector	
Connection	Cross-section Cable colour	Hydronic M PIN	Hydronic M-II PIN
Metering pump	1,5 <sup>2</sup> GN	C4 →	A1
Terminal 31	4 <sup>2</sup> BN	C3 →	A2*
Terminal 30	4 <sup>2</sup> RD	C2 →	A3*
Plus signal to the battery power switch	1,5 <sup>2</sup> WH/RD	C1 →	A4
Plus signal to the relay solenoid valve	–	B4 →	B1
Diagnosis	1 <sup>2</sup> BU	B3 →	B4
Plus signal from the ADR auxiliary drive	1 <sup>2</sup> VT	B2 →	B3
External control Water pump	–	B1	remains unused**
Relay, blower	1 <sup>2</sup> RD/YE	A4 →	C1
Plus signal (D+) to the heater – in ADR mode	1 <sup>2</sup> VT/GN	A3 →	C2
Temperature drop	–	A2 →	C3
Heater ON	1 <sup>2</sup> YE	A1 →	C4

\* Connection of the cables to connector B2 requires a reduction in the cable cross-section to 2.5 mm<sup>2</sup>.

\*\* External control of the water pump is not planned for Hydronic M-II.



## 5 Electrical system

### Parts list for circuit diagram, heater and cable harness - 12 Volt / 24 Volt / ADR

-A10	Control box
-XS1	Connector housing, heater signals
-B1	Temperature sensor
-B2	Overheating sensor
-B5	Flame sensor
-M2	Burner motor with HAL sensor
-M10	Water pump
-R1	Glow plug
-R5	Glow plug 2
-XB3/11	Bush housing 1, control box plug-in connection
-XB9	Bush housing, water pump plug-in connection
a	Interface, heater / cable harness
b	Activation, vehicle fan
d	For ADR: Generator D+ input (generator)
o	For ADR: Power take-off NA+ input
-A30	Fuse holder, 3 pin
-F1	Main fuse
-F2	Fuse, vehicle fan
-F3	Fuse, actuation
-K1	Fan relay
-K2	Battery main switch (operation, e.g. controlled via ignition lock)
-K6	Relay, solenoid valve
-RA1	Diode
-S2	Battery isolating switch (emergency off function for ADR etc.)
-XB1	Bush housing, heater signals
-XB7	Relay block
-XB7/1	Relay block 2
-XB8	Bush housing, metering pump plug-in connection
-XB8/1	Bush housing, metering pump plug-in connection
-XB11	Bush housing, EDiTH diagnostics tool
-XB13	Bush housing, NA / D+ input plug-in connection
-XS8/1	Connector housing, metering pump connection
-XS11	Bush housing, EDiTH diagnostics tool
s	Connection, EDiTH diagnostics tool
-XS13	Connector housing, NA / D+ input plug-in connection
-Y1	Fuel metering pump
a	Interface, heater / cable harness
c	to the control unit
f, x	Switch cable S+, insulate cable and tie back
i	ADR feedback to the control unit
t	Temperature drop
v	fused Plus activation for relay K6 at terminal 30 Plus activation for electric solenoid valve, terminal 87

#### 12-pin connection pin assignment (-XB1)

PIN-No.	Connection	Conductor cross-section mm <sup>2</sup> / Cable colour
A1	Metering pump	1 / GN
B1	Solenoid valve, optional	1,0 / -
C1	Relay, blower	1,0 / RD/YE
A2	Terminal 31	2,5 / (4,0) BN
B2	-	-
C2	ADR D+	1,0 / VT/GN
A3	Terminal 30	2,5 / (4,0) RD
B3	ADR HA+	1,0 / VT
C3	Temperature drop	1,0 / -
A4	Plus signal output	1,5 / WH/RD
B4	Diagnosis (HELJED)	0,75 BU/WH
C4	Heater ON	0,75 YE

Connectors and bush housings are shown from the cable inlet side.

#### Cable colours

RD	red	GR	grey	BK	black
BU	blue	YE	yellow	GN	green
WH	white	VT	violet	BN	brown
OR	orange				

# 5 Electrical system

## Heater circuit diagram – 12 Volt / 24 Volt / ADR

X:15 Ign (+)

X:58 Light (+)

X:30 Bat (+)

X:31 Bat (-)

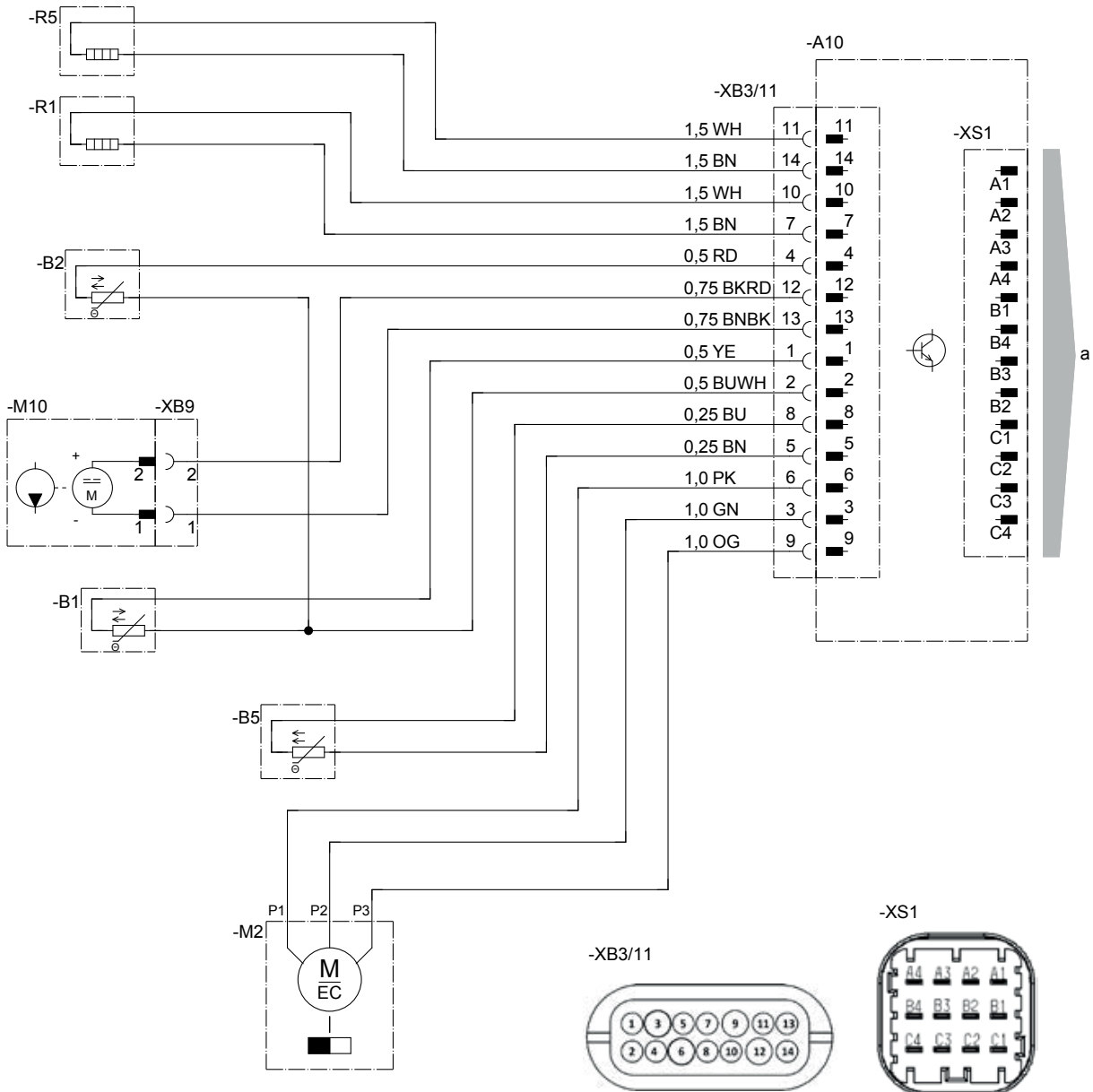

25.2435.00.9602



# 5 Electrical system

## Cable harness circuit diagram – 12 Volt / 24 Volt / ADR

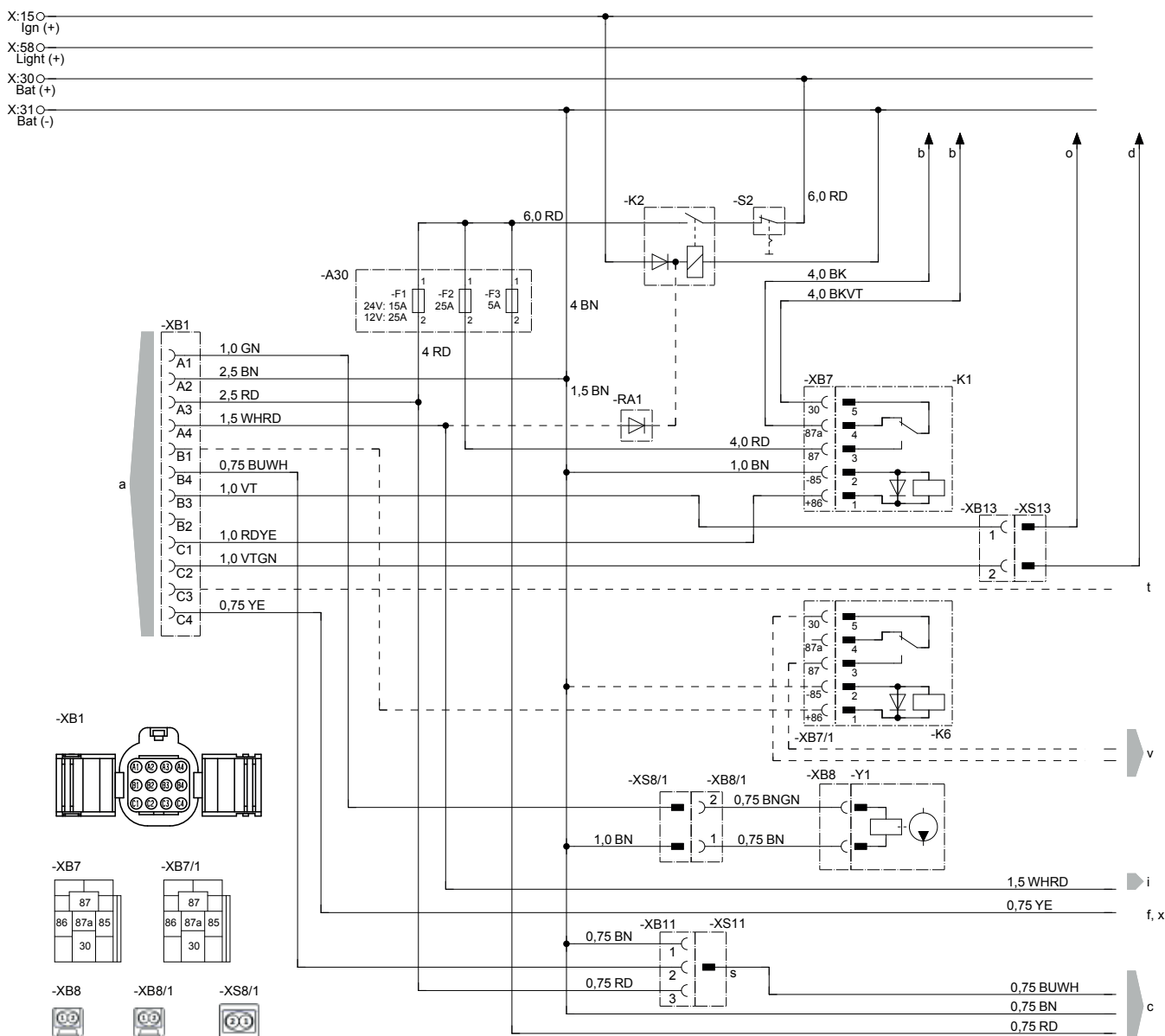

25.2435.00.9603

Parts list page 31

# 5 Electrical system

## Circuit diagram – EasyStart Timer

X:15 Ign (+)

X:58 Light (+)

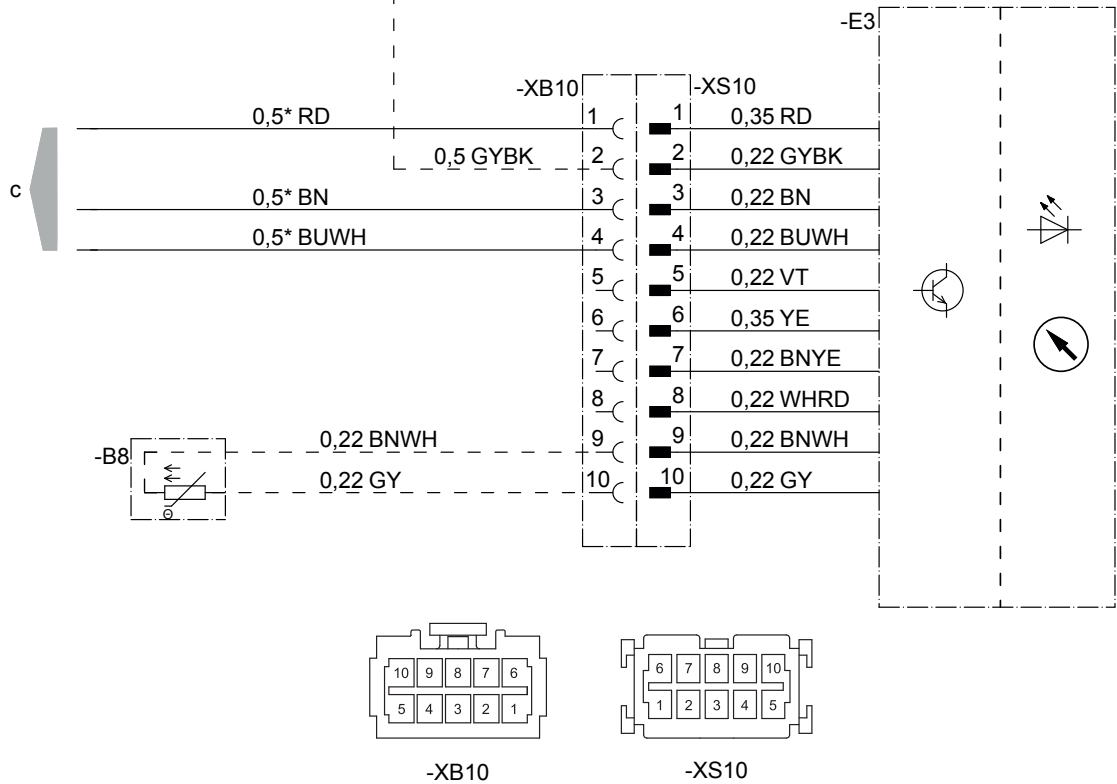

22.1000.34.9701

- B8 Room temperature sensor (optional)
- E3 EasyStart Timer
- c to the cable harness

Connectors and bush housings are shown from the cable inlet side.

### **i** Note

Further circuit diagrams for the EasyStart Timer are printed in the Installation Instructions Plus, these are available to view and download from the Service Portal.

## 5 Electrical system

### Circuit diagram – EasyStart Timer-ADR

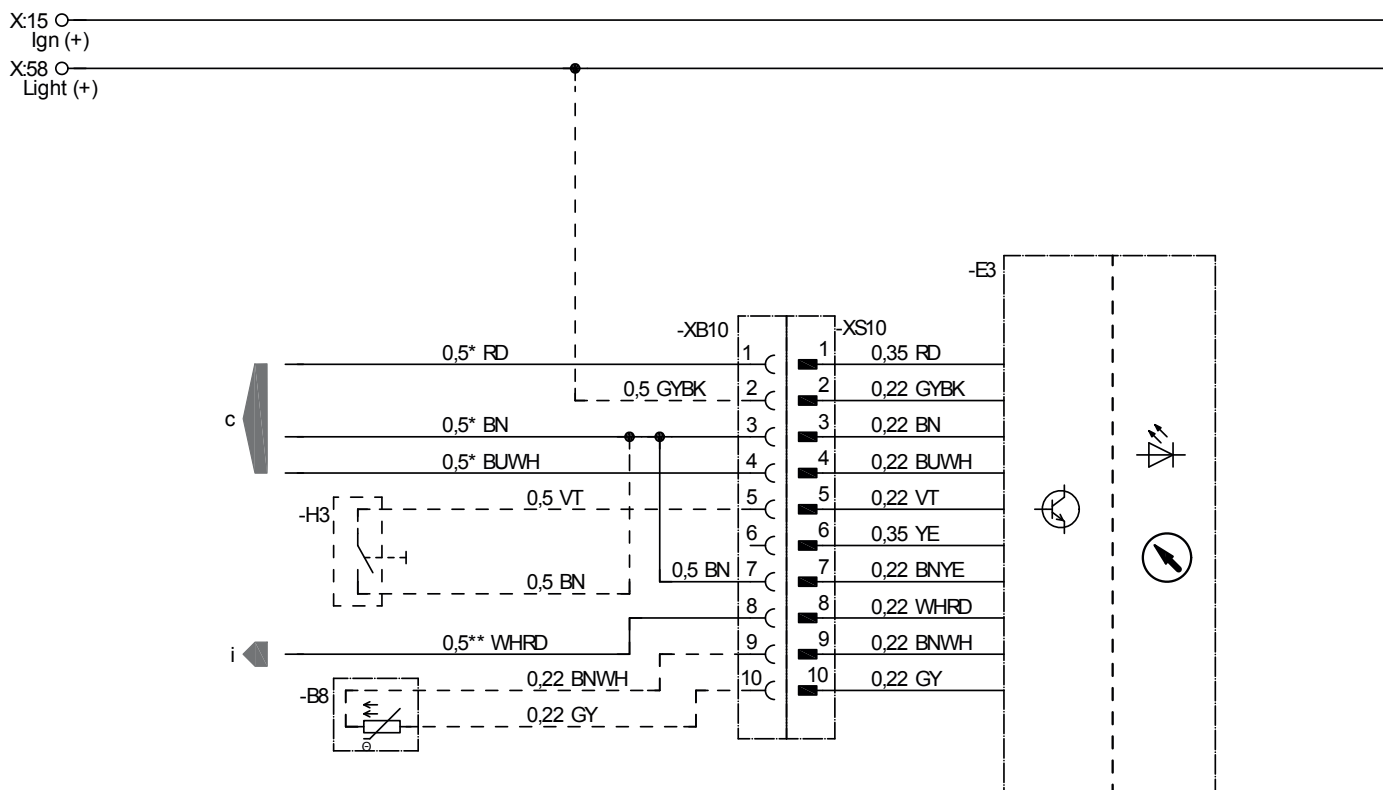

\* Hydronic MII 0,75

\*\* Hydronic MII 1,5

22.1000.34.9710

- B8 Room temperature sensor (optional)
- E3 EasyStart Timer
- H3 EasyStart Timer button
- c to the cable harness
- i ADR feedback from the heater

Connectors and bush housings are shown from the cable inlet side.



#### Note

Further circuit diagrams for the EasyStart Timer are printed in the Installation Instructions Plus, these are available to view and download from the Service Portal.

# 5 Electrical system

## Circuit diagram – EasyStart Remote+

X:15 ○  
Ign (+)

X:58 ○  
Light (+)

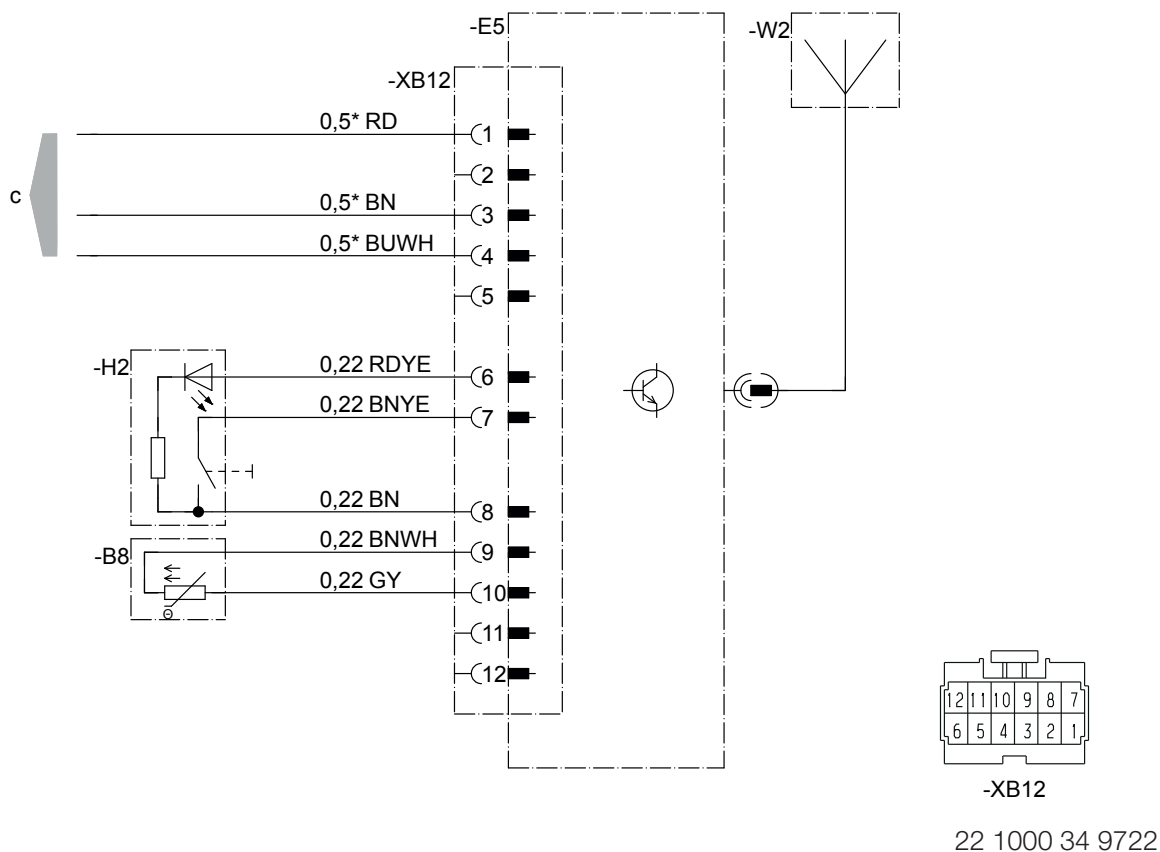

- B8 Room temperature sensor
- E5 Stationary unit, EasyStart Remote+
- H2 Button
- W2 Antenna
- c to the cable harness

Connectors and bush housings are shown from the cable inlet side.

### **i** Note

Further circuit diagrams for the EasyStart Remote+ are printed in the Installation Instructions Plus, these are available to view and download from the Service Portal.



## 5 Electrical system

### Circuit diagram – EasyStart Remote

X:15 ○  
Ign (+)

X:58 ○  
Light (+)

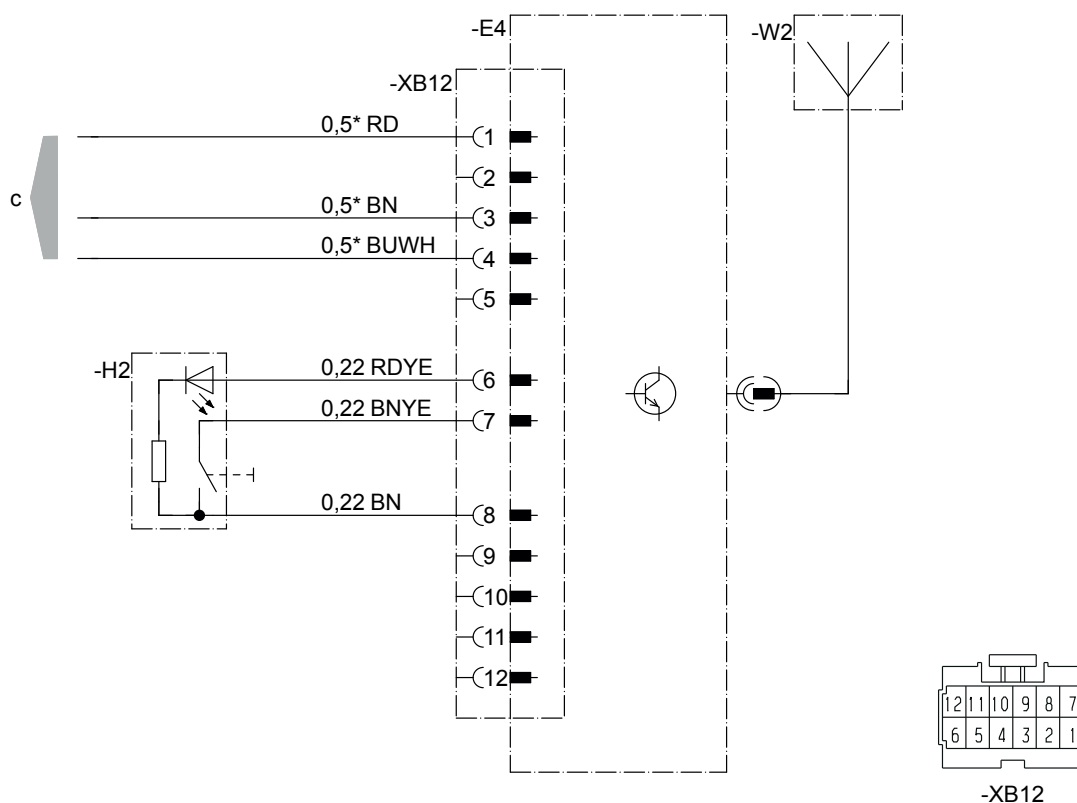

-XB12

22.1000.34.9733

-E4      Stationary unit EasyStart Remote  
-H2      Button  
-W2      Antenna  
c        to the cable harness

Connectors and bush housings are shown from the cable inlet side.



#### Note

Further circuit diagrams for the EasyStart Remote are printed in the Installation Instructions Plus, these are available to view and download from the Service Portal.



# 5 Electrical system

## Circuit diagram – EasyStart Select

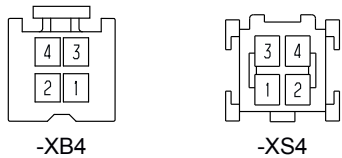
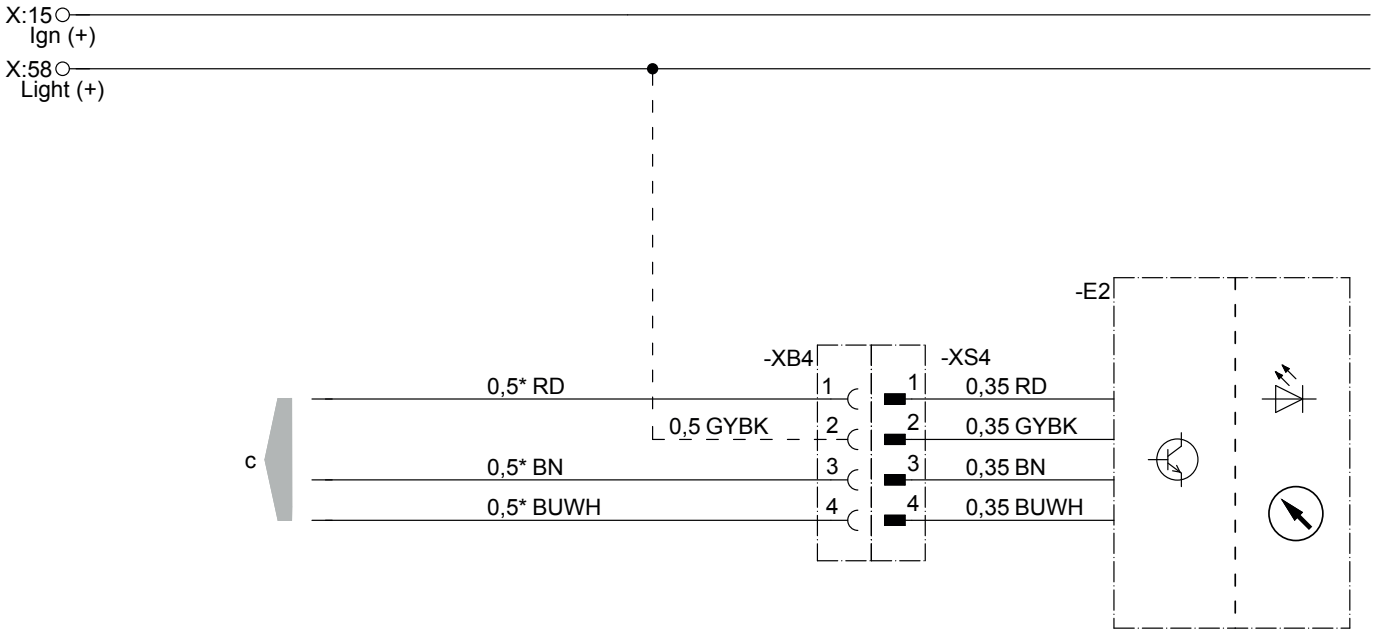

22.1000.34.9734

-E2 EasyStart Select  
c to the cable harness

Connectors and bush housings are shown from the cable inlet side.



### Note

Further circuit diagrams for the EasyStart Select are printed in the Installation Instructions Plus, these are available to view and download from the Service Portal.



## 5 Electrical system

### Circuit diagram – EasyStart Web

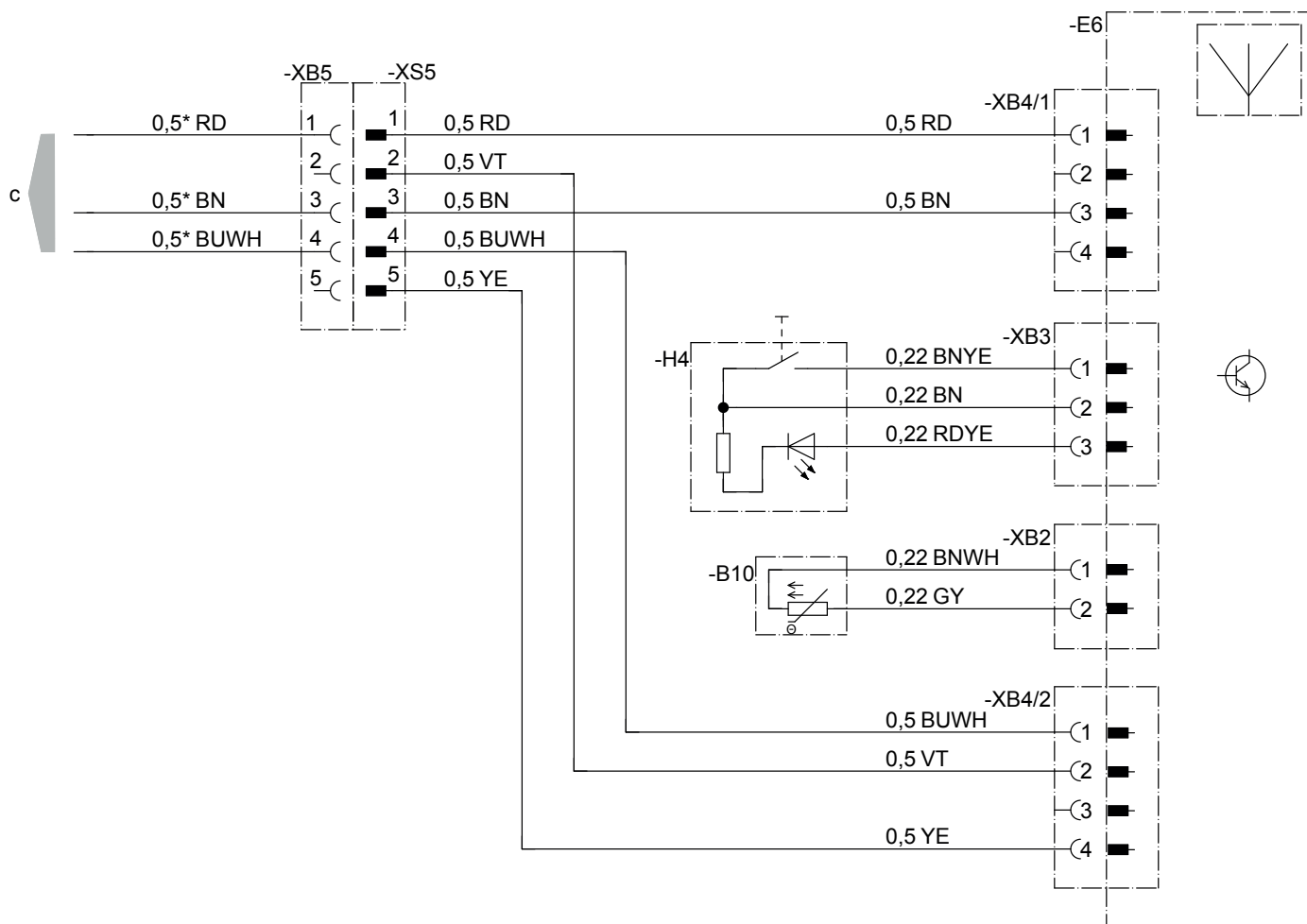

22.1000.34.9719

- B10 Room temperature sensor
- E6 EasyStart Web
- H4 Button
- c to the cable harness

Connectors and bush housings are shown from the cable inlet side.

#### Note

Further circuit diagrams for the EasyStart Web are printed in the Installation Instructions Plus, these are available to view and download from the Service Portal.

## 6 Troubleshooting / Maintenance / Service

---

### In case of faults, please check the following points

- If the heater does not start after being switched on:
  - Switch the heater off and on again.
- If the heater still does not start, check whether:
  - There is fuel in the tank?
  - The fuses are OK?
  - The electrical cables, connections etc. are OK?
  - Anything is clogging the combustion air supply or exhaust system?
- Check the openings of the combustion air supply and exhaust system after longer standstill periods, clean if necessary!

### Troubleshooting

If the heater remains faulty even after these points have been checked, or another malfunction occurs in your heater, please contact:

- For installation ex works, your contract workshop.
- For subsequent installation, the workshop who installed your heater.

#### **Please note!**

Please note that warranty claims can be become void if the heater is changed by a third party or by this installation of third party parts.

### Maintenance instructions

- Switch the heater on once a month for about 10 minutes, even outside the heating period.
- Before the heating period starts, the heater should undergo a trial run. If persistent extreme smoke develops, unusual burning noises or a clear fuel smell can be perceived or if electric / electronic parts heat up, the heater must be switched off and put out of service by removing the fuse.  
In this case, the heater should not be started up again until it has been checked by qualified staff who have been trained on Eberspächer heaters.

### Service

#### Technical Support

If you have any technical questions or problems with the heater, the control unit or the operating software, please contact the following service address:

support-UK@eberspaecher.com



## 7 Environment

### Certification

The high quality of Eberspächer's products is the key to our success.

To guarantee this quality, we have organised all work processes in the company along the lines of quality management (QM).

Even so, we still pursue a large number of activities for continuous improvement of product quality in order to keep pace with the similarly constantly growing requirements made by our customers.

All the steps necessary for quality assurance are stipulated in international standards.

This quality is to be considered in a total sense.

It affects products, procedures and customer/supplier relationships.

Officially approved public experts assess the system and the corresponding certification company awards a certificate.

Eberspächer Climate Control Systems GmbH & Co.KG has already qualified for the following standards:

**Quality management as per  
ISO TS 9001:2015 and IATF 16949:2016**

**Environment management system as per  
ISO 14001:2015**

### Disposal

#### Disposal of materials

Old devices, defect components and packaging material can all be separated and sorted into pure-grade factions so that all parts can be disposed of as required in an environment-friendly manner or recycled where applicable.

Electric motors, controllers and sensors (e.g. temperature sensors) are deemed to be "electronic scrap".

#### Dismantling the heater

The heater is dismantled according to the repair stages in the current troubleshooting / repair instructions.

#### Packaging

The packaging of the heater can be kept in case it has to be sent back.

### EU Declaration of Conformity

We herewith declare that the version of the heater placed on the market by us conforms to the applicable provisions of the following EU Directive.

EU Directive 2014/30/EU



The full Declaration of Conformity can be viewed and downloaded from the download centre under [www.eberspaecher.com](http://www.eberspaecher.com).

## 8 List

---

### List of abbreviations

**ADR**

European agreement about the international transport of dangerous goods on the road.

**EC type approval / EMC type approval**

Permit awarded by the Federal Vehicle Office for the production of a heater for installation in motorised vehicles.

**EMC directive**

Electromagnetic compatibility.

**JE partner**

Eberspächer partner.

**FAME** (Biodiesel)

(FAME for diesel engines according to DIN EN 14 214)



[www.krueger.co.uk](http://www.krueger.co.uk)

Eberspächer dealer



Eberspächer®

[www.eberspaecher.com](http://www.eberspaecher.com)

All information in this manual is copyright of Eberspächer