

Circuit Diagrams – EasyStart Select

For Hydronic, Hydronic II, Hydronic II C, Hydronic II Comfort, Hydronic M II, Hydronic S3

EN

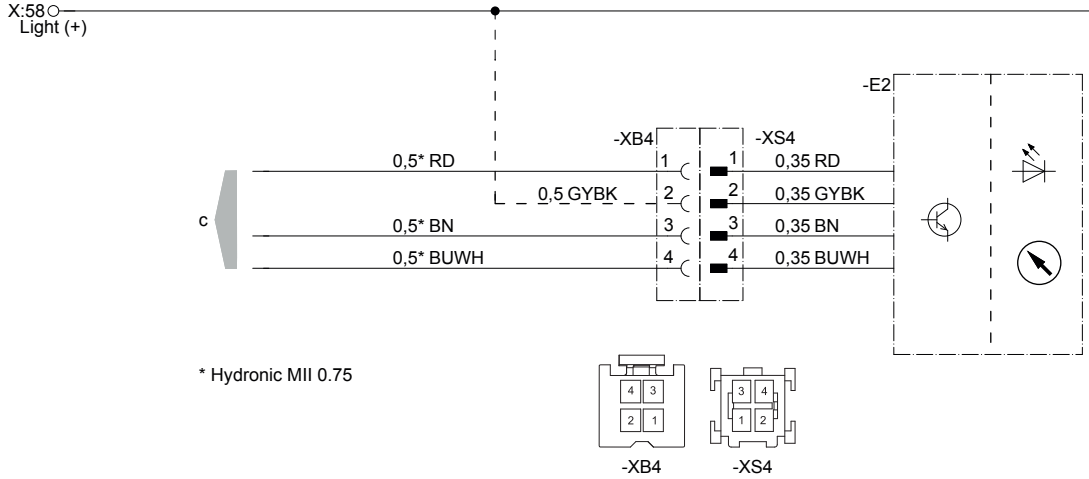

22 1000 34 97 34

Circuit Diagrams – EasyStart Select

Connection to Airtronic, Airtronic M, Airtronic L

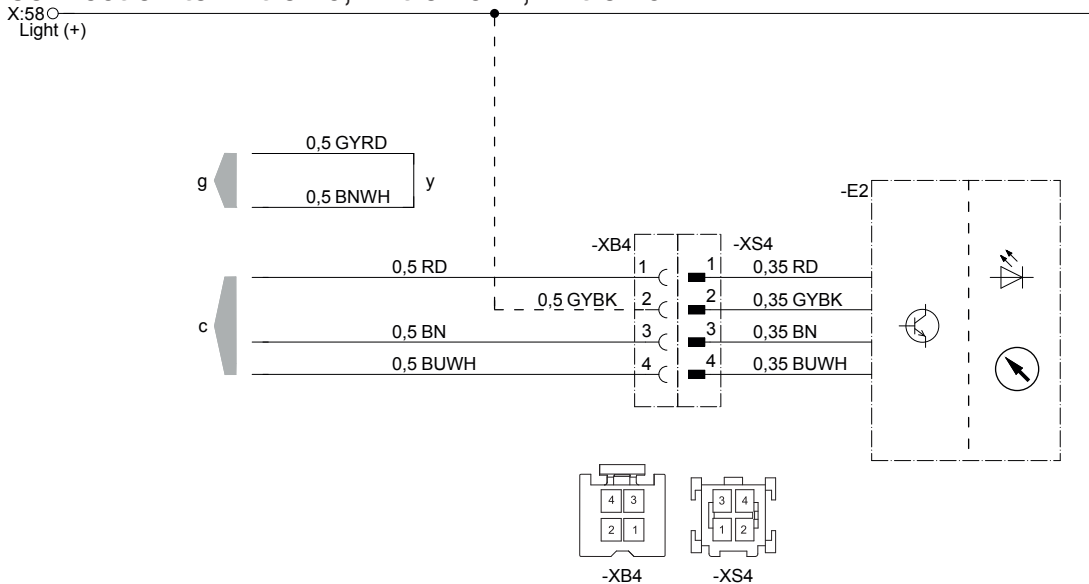

22 1000 34 97 35

EN

-E2 EasyStart Select

c to the heater

g to the heater

y Connect cables and insulate

Cable colours

RD	red	GY	grey	BK	black
BU	blue	YE	yellow	GN	green
WH	white	VT	violet	BN	brown

Connector housing pin assignment -XS4 / -XB4

Pin	Signal	Cable colour	Cross-section XS4	Cross-section XB4
1	Terminal 30	red	0.35 mm ²	0.5 mm ²
2	Terminal 58	grey / black	0.35 mm ²	0.5 mm ²
3	Terminal 31	brown	0.35 mm ²	0.5 mm ²
4	Diagnosis	blue / white	0.35 mm ²	0.5 mm ²

Connector housing chamber assignment (assignment seen from the cable inlet side)

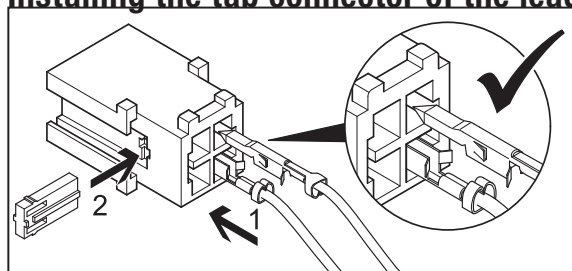
Installing the tab connector of the lead harness

i Please note!

- When installing the connector, ensure that the locking tangs always face the middle of the connector. Only in this position to the tangs latch into the housing (see sketch).
- Please find further information on the devices installation and connection on the enclosed CD.

Headquarters:

Eberspächer Climate Control Systems
 GmbH & Co. KG
 Eberspächerstraße 24
 73730 Esslingen
 Hotline: 03976 2350235
 Fax hotline: 01805 262624
 info@eberspaecher.com
 www.eberspaecher.com



www.krueger.co.uk

Eberspächer dealer



Eberspächer®

www.eberspaecher.com

All information in this manual is copyright of Eberspächer