

TROUBLESHOOTING AND REPAIR INSTRUCTIONS

Eberspächer Airtronic D2L & D4L



The repair instructions are valid for the following engine-independent air heaters:

Air heaters for diesel fuel

Airtronic S2, D2L, 12 V
Airtronic S2, D2L, 24 V
Airtronic M2, D4L, 12 V
Airtronic M2, D4L, 24 V
Airtronic M2, D4R, 12 V

Order No.

25.2721.05.0000
25.2726.05.0000
25.2720.05.0000
25.2729.05.0000
25.2746.05.0000

Order No. incl. EasyStart Pro

25.2753.05.0000
25.2754.05.0000
25.2755.05.0000
25.2756.05.0000
25.2757.05.0000

Air heaters for petrol

Airtronic M2, B4L, 12 V

Order No.

20.1987.05.0000

Order No. incl. EasyStart Pro

20.2032.05.0000

A WORLD OF COMFORT



Chapter	Chapter title	Page	Chapter contents
1	Introduction		
1.1	Concept of this document	5	
1.2	General information	5	
1.3	Reference documents	5	
1.4	Special text formats and presentations	5	
1.4.1	Lists	5	
1.4.2	Cross references	5	
1.5	Picture symbols	5	
1.6	Intended use	6	
1.6.1	Range of application of the heater	6	
1.6.2	Intended use of the heater	6	
1.7	Non-intended use	6	
1.8	Safety instructions	6	
1.9	Warranty and liability	6	
1.10	Accident prevention	6	
1.11	Functional test following a repair	6	
2	Function and operation		
2.1	Functional description	7	
2.1.1	Switching on	7	
2.1.2	Temperature selection with the control unit	7	
2.1.3	Control in heating mode	7	
2.1.4	Ventilator mode	7	
2.1.5	Switch off	7	
2.2	Control and safety devices	7	
2.2.1	Forced shutdown in ADR mode (for 24 V heaters for diesel fuel only)	8	
3	Technical data		
3.1	Airtronic S2 D2L	9	
3.2	Airtronic M2 D4L	10	
3.3	Airtronic M2 D4R	11	
3.4	Airtronic M2 B4L	12	
3.5	Control values	13	
3.5.1	Resistance values	13	
3.5.2	Exhaust value	13	
3.5.3	Checking the “external” temperature sensor	13	

4	Troubleshooting	
4.1	What to check first in case of faults	13
4.2	Control box is locked	13
4.3	Unlocking the control box	13
4.4	Overview of the test equipment and control units suitable for diagnosis	14
4.5	Notes on heater diagnosis with control units	14
4.5.1	Easy Start Pro	14
4.5.2	EasyStart Web	14
4.5.3	EasyStart Remote+	14
4.6	Flashing code display	15
4.6.1	Function display and error output via flashing code	15
4.7	Fault code table	16
5	Repair instructions	
5.1	Special tool	21
5.1.1	Release tool	21
5.2	Repair steps	21
5.3	Exploded drawing of heater	22
5.4	Dismantle the heater	23
5.4.1	Removing the upper jacket shell	23
5.4.2	Removing the control box	23
5.4.3	Removing the glow plug	24
5.4.4	Visual inspection of glow plug lining	25
5.4.5	Removing the heater	25
5.4.6	Removing the outlet hood	25
5.4.7	Removing lower jacket shell	26
5.4.8	Testing the combination sensor	26
5.4.9	Removing the combination sensor	26
5.4.10	Removing the fan	28
5.4.11	Removing the combustion chamber	28
5.4.12	Removing the heat exchanger	28
5.5	Assembling the heater	29
5.5.1	Installing the heat exchanger	29
5.5.2	Installing the glow plug lining	29
5.5.3	Installing the combustion chamber	29
5.5.4	Installing the fan	30
5.5.5	Installing the combination sensor	30
5.5.6	Install glow plug	30
5.5.7	Connecting the glow plug	31
5.5.8	Connecting the lead harness	31
5.5.9	Connecting the combination sensor	31
5.5.10	Installing the control box	32
5.5.11	Mounting the lower jacket shell	32
5.5.12	Installing the outlet hood	32

5.5.13 Mounting the upper jacket shell	33
5.5.14 Installing the heater	33
5.6 Checking the fuel supply	34
5.6.1 Manual measurement of the fuel quantity	34
5.6.2 Measuring the fuel quantity with EasyScan	34
6 Electrics	
6.1 Heater wiring	35
6.2 Parts list for the Airtronic S2 and Airtronic M2 circuit diagrams	35
6.3 Circuit diagrams for Airtronic	36
6.3.1 Heater	36
6.3.2 Cable harness	37
6.3.3 Cable harness with ADR (24 V only)	38
6.4 Circuit diagrams, control units TP 7.0 (for 12 V only)	39
6.4.1 EasyStart Timer	39
6.4.2 EasyStart Remote+	40
6.4.3 Easy Start Remote	41
6.4.4 EasyStart Select	42
6.4.5 EasyStart Web	43
6.5 Circuit diagrams, control units TP 7.1	44
6.5.1 Easy Start Pro	44
7 Service	
7.1 Technical Support	45
8 Environment	
8.1 Certification	45
8.2 Disposal	45

1 Introduction

1.1 Concept of this document

This document assists the workshop with troubleshooting and repair of the heater.

The document is divided into the following chapters to make it easier to find information quickly.

1 Introduction

Important, introductory information about the structure of this documentation, safety and intended use of the heater

2 Function and operation

Basic information on the function and operation of the heater

3 Technical data

Technical data of the heater

4 Troubleshooting

Information about unlocking the control box and the fault codes of the heater, their meaning and troubleshooting measures / remedies based on a clear table

5 Repair instructions

Information about special tools, dismantling and assembly of the heater's components as well as a component drawing

6 Electrics / Circuit diagram

Information on the electrical components and circuit diagrams of the heater and the cable harness

7 Environment

Information about certification and disposal of the heater

8 Service

Information about setup times and technical support

1.2 General information

This document is used to correct faults and to carry out repairs for the heaters listed on the title page, and is valid to the exclusion of all liability claims. The necessary work may only be carried out by appropriately trained personnel of an Eberspächer service partner.

Depending on the version or revision status of the heater, differences may occur compared to this documentation. Please check this before carrying out the repair and take any possible differences into account.

1.3 Reference documents

Technical description

Describes the function and proper installation and contains all information necessary for safe operation of the heater.

Spare parts list

Contains the information necessary for ordering spare parts.

Installation recommendation (heater-dependent)

Describes vehicle-specific installation situations.

Installation Instructions Plus

Supplementary information on heaters and control units.

1.4 Special text formats and presentations

Special text formats and picture symbols are used in this document to emphasise different situations and subjects. Please refer to the following examples for their meanings and appropriate action.

1.4.1 Lists

- This dot (•) indicates a list or action step, introduced by a heading.
 - If an indented dash (–) follows a “dot”, this list/action step is a sub-section/secondary step of the black dot.

1.4.2 Cross references

Underlined blue text denotes a cross-reference, which can be clicked in the PDF format. The part of the document named in the text is then displayed.

1.5 Picture symbols



Regulation!

This information indicates a statutory regulation. Any violation of these regulations results in expiry of the type-approval for the heater and exclusion of any guarantee and liability claims against Eberspächer Climate Control Systems GmbH & Co. KG.



Danger!

This information indicates an imminent risk to life and limb. Failure to avoid this hazard will result in death or severe injuries.

→ This arrow indicates appropriate precautions to take to avert the danger.



Warning!

This information indicates a potentially imminent risk to life and limb. Failure to avoid this hazard can result in death or severe injuries.

→ This arrow indicates appropriate precautions to take to avert the danger.



Caution!

This information indicates a potentially imminent risk. Ignoring this information can result in slight or minor injuries.

→ This arrow indicates appropriate precautions to take to avert the danger.

i Note

These remarks contain recommendations for use and useful tips for the operation, installation and repair of the heater.

1.6 Intended use

1.6.1 Range of application of the heater

The air heater operating independently of an engine is intended for installation in the following vehicles:

- All types of vehicles (max. 8 seats + driver's seat) and their trailers
- Construction machinery
- Agricultural machinery
- Boats, ships and yachts (only diesel heaters)
- Camper vans

1.6.2 Intended use of the heater

- Pre-heating, de-misting windows
- Heating and keeping the following warm:
 - Driver and working cabs, ship's cabins
 - Freight compartments
 - Passenger and crew compartments
 - Camper vans

i Note

Only use and operate the heater within the scope of the intended use stated by the manufacturer and in compliance with the documentation enclosed with each heater.

1.7 Non-intended use

On account of its functional purpose, the heater is not approved for the following applications:

- Long-term continuous operation, e.g. for heating:
 - Residential rooms
 - Garages
 - Work huts, weekend homes and hunting lodges
 - Houseboats, etc.
- Heating or drying of:
 - Living creatures (people or animals) by blowing hot air directly at them
 - Objects
 - Blowing hot air into containers

1.8 Safety instructions

 **Danger!**

Fire hazard. Risk of poisoning due to exhaust gases.

Improper repair or installation can result in toxic exhaust gases getting into the interior of the vehicle or a fire.

- Repair and installation of the heater by authorised and trained skilled personnel only.
- Use original spare parts only.
- Comply with the official regulations.
- Take into account and follow this document and all applicable documentation.

i Note

- Comply with the vehicle manufacturer's instructions.
- In case of electric welding work on the vehicle, disconnect the positive pole from the battery and connect it to ground.

1.9 Warranty and liability

Eberspächer Climate Control Systems GmbH & Co. KG does not accept any liability whatsoever for defects and damage, which are due to installation or repair by unauthorised and untrained persons.

Compliance with official regulations and the safety instructions is prerequisite for liability claims. Failure to comply with official regulations and safety instructions leads to exclusion of any liability of the manufacturer.

1.10 Accident prevention

Always follow all general accident prevention regulations as well as workshop and operating safety instructions.

1.11 Functional test following a repair

- After installing the heater, the whole fuel supply system must be carefully vented: please refer to and follow the vehicle manufacturer's instructions.
- Switch on the heater at the control unit and during the trial run, check all water and fuel connections for leaks and tight fit.
- Correct any faults during operation with the help of diagnostic equipment or the control unit.

i Note

The function of the heater is described in detail in the "Technical Description" document.

Emergency shutdown – EMERGENCY OFF

In an emergency carry out an emergency shutdown as follows:

- Switch off the heater via the control unit or disconnect it from the power supply (remove fuse / disconnect battery).

2 Function and operation

2.1 Functional description

2.1.1 Switching on

When the heater is switched on, the control lamp/illuminated ring in the control unit lights up. The glow plug is switched on and the fan starts at low speed.

i Note

- If there is still too much residual heat in the heat exchanger from when the heater was last used, firstly only the fan starts up (cold blowing). Once the residual heat has been cleared, the heater starts.
- Only the burner motor is activated for the “Ventilate” function.

Starting the Airtronic

After approx. 65 seconds, the fuel supply starts and the fuel / air mixture in the combustion chamber ignites. After the flame sensor has detected the flame, the glow plug is switched off after 60 seconds. The heater is now in normal operation.

Starting the Airtronic M

After approx. 60 seconds, the fuel supply starts and the fuel / air mixture in the combustion chamber ignites. After the flame sensor has detected the flame, the glow plug is switched off after approx. 90 seconds. The heater is now in normal operation. After a further 120 seconds, the heater has reached the “POWER” control stage (maximum fuel quantity and maximum fan speed).

2.1.2 Temperature selection with the control unit

The control unit can be used to preselect the required interior temperature of the space to be heated. The temperature can be within the range from +10 °C to +30 °C. It depends on the selected heater, on the size of the space to be heated and the prevailing outdoor temperature. The setting to be selected at the control unit is an empirical value.

2.1.3 Control in heating mode

During heating mode, the room temperature or the temperature of the hot air drawn in is measured constantly. The control begins on approaching the required (preselected) temperature. The heating output is controlled continuously, so that fine adjustment of the heat flow supplied by the heater to the heat requirement is possible. The fan speed and fuel quantity correspond to the respective control stage.

If the set temperature is still exceeded in the smallest control stage, the heater goes to the “OFF” stage with the fan running on for approx. 4 minutes to cool down. The fan then continues running at minimum speed (circulation mode) until the restart or is switched off (fresh air mode with external temperature sensor).

2.1.4 Ventilator mode

The EasyStart R+ and EasyStart Pro control units and the mini controller can be used to activate the “Ventilate” function. The “Heat / Ventilate” switch is also required for the module timer and the control unit, whereby for fan operation, the “Heat / Ventilate” switch must be actuated first and then the heater must be switched on. The fan runs in ventilator mode with constant speed.

2.1.5 Switch off

When the heater is switched off, the control lamp goes out and the fuel delivery is switched off. The fan runs on for approx. 4 minutes to cool down. The glow plug is switched on for approx. 40 seconds to clean it during the fan after-running.

Special case:

If no fuel has been supplied or if the heater is in the “OFF” stage until it is switched off, the heater is stopped without any after running.

2.2 Control and safety devices

- If the heater does not ignite within 90 seconds after the fuel starts to pump, the start is repeated. If the heater still does not ignite after another 90 seconds of pumping fuel, a safety lock-out occurs, i.e. the fuel supply is off and the fan continues to run for approx. 4 minutes.
- If the flame goes off by itself during operation, the heater is initially restarted. If the heater does not ignite within 90 seconds after the fuel delivery has started, or ignites but goes out again within 15 minutes, a safety lock-out occurs, i.e. the fuel delivery is switched off and the fan carries on running for approx. 4 minutes. The safety lock-out can be cancelled by briefly switching off and on again.

i Note

Do not repeat the switching off / on routine more than twice.

- In the event of overheating, the combined sensor (flame sensor/overheating sensor) triggers, the fuel supply is interrupted and a safety lock-out occurs. Once the cause of the overheating has been eliminated, the heater can be re-started by switching off and on again.
- If the lower or upper voltage limit is reached, a shutdown on faults takes place after 20 seconds.
- The heater does not start up when the glow plug or the fan motor is defective or when the electric lead to the metering pump is interrupted.
- If the combined sensor (flame/overheating sensor) is defective or the electric lead is interrupted, the heater starts and the safety lockout (shutdown on faults) does not take place until during the start phase.
- The speed of the fan motor is monitored continuously. If the fan motor is not running or if the speed deviates by more than 10 %, safety lockout (shutdown on faults) takes place after 30 seconds.
- When the heater is switched off, the glow plug is switched on for 40 seconds (after glowing) while the fan carries on running to clean off any combustion residues.

2.2.1 Forced shutdown in ADR mode (for 24 V heaters for diesel fuel only)

In vehicles for the transport of dangerous goods (e.g. tanker trucks), the heater must be switched off before the truck drives into a danger area (refinery, petrol station, etc.).

Failure to comply results in the heater switching off automatically when:

- the vehicle engine is switched off.
- an additional unit is switched on (auxiliary drive for unloading pump, etc.).

The fan then carries on running briefly for max. 40 seconds.

3 Technical data

3.1 Airtronic S2 D2L

Heater type	Airtronic		
Heater	Airtronic S2		
Version	D2L		
Heating medium	Air		
Fuel	Diesel – standard commercially available (EN 590)		
For information on “Fuel quality” and “Fuel at low temperatures” see page 8.			
Control of the heat flow	Maximum	Minimum	Off
Heat flow (watt)	2200	850	–
Hot air throughput without backpressure (kg/h) with hood 75 mm	105	42	13
Fuel consumption (l/h)	0.28	0.1	–
Average electrical power consumption (watt)	during operation	31	6
	while starting	≤ 100	
Closed-circuit power consumption	100 µA		
Rated voltage	12 volt or 24 volt		
Operating range			
Lower voltage limit: An undervoltage protector installed in the control box switches off the heater if the voltage limit is reached.	approx. 10.5 volt or approx. 21 volt Undervoltage protection response time: 20 seconds ±1		
Upper voltage limit: An overvoltage protector (surge suppressor) installed in the control box switches off the heater if the voltage limit is reached.	approx. 16 volt or approx. 32 volt Overvoltage protection response time: 20 seconds ±1		
Ambient temperature	Heater	during operation	–40 °C to +70 °C
		not in operation	–40 °C to +85 °C
	Metering pump	during operation	–40 °C to +50 °C
		not in operation	–40 °C to +125 °C
Hot air intake temperature	max. +40 °C		
Combustion air temperature	max. +50 °C		
Interference suppression	Suppression class 5 to EN 55025		
Degree of protection in accordance with ISO 20653	during operation	IP5k4k	
	not in operation	IP5k6k and IP5k9k	
Weight	approx. 2.7 kg		
Ventilation mode	possible		

Attention!

Safety instructions for technical data!

Failure to comply with the technical data can result in malfunctions.

Note

Provided no other values are given, the technical data provided is with the usual tolerances of ±10 % at rated voltage, 20 °C ambient temperature and reference altitude Esslingen.

3.2 Airtronic M2 D4L

Heater type	Airtronic		
Heater	Airtronic M2		
Version	D4L		
Heating medium	Air		
Fuel	Diesel – standard commercially available (EN 590)		
For information on “Fuel quality” and “Fuel at low temperatures” see page 9.			
Control of the heat flow	Maximum	Minimum	Off
Heat flow (watt)	4000	900	–
Hot air throughput without backpressure (kg/h) with hood 90 mm	180	60	22
Fuel consumption (l/h)	0.51	0.11	–
Average electrical power consumption (watt)	during operation	42	6
	while starting	≤ 100	
Closed-circuit power consumption	100 µA		
Rated voltage	12 volt or 24 volt		
Operating range			
Lower voltage limit:	approx. 10.5 volt or approx. 21 volt		
An undervoltage protector installed in the control box switches off the heater if the voltage limit is reached.	Undervoltage protection response time: 20 seconds ±1		
Upper voltage limit:	approx. 16 volt or approx. 32 volt		
An overvoltage protector (surge suppressor) installed in the control box switches off the heater if the voltage limit is reached.	Overvoltage protection response time: 20 seconds ±1		
Ambient temperature	Heater	during operation	–40 °C to +70 °C
		not in operation	–40 °C to +85 °C
	Metering	during operation	–40 °C to +50 °C
	pump	not in operation	–40 °C to +125 °C
Hot air intake temperature	max. +40 °C		
Combustion air temperature	max. +50 °C		
Interference suppression	Suppression class 5 to EN 55025		
Degree of protection in accordance with ISO 20653	during operation	IP5k4k	
	not in operation	IP5k6k and IP5k9k	
Weight	approx. 4.5 kg		
Ventilation mode	possible		

Attention!
Safety instructions for technical data!

Failure to comply with the technical data can result in malfunctions.

Note

Provided no other values are given, the technical data provided is with the usual tolerances of ±10 % at rated voltage, 20 °C ambient temperature and reference altitude Esslingen.

3.3 Airtronic M2 D4R

Heater type	Airtronic		
Heater	Airtronic M2		
Version	D4R		
Heating medium	Air		
Fuel	Diesel – standard commercially available (EN 590)		
For information on “Fuel quality” and “Fuel at low temperatures” see page 10.			
Control of the heat flow	Maximum	Minimum	Off
Heat flow (watt)	4000	900	–
Hot air throughput without backpressure (kg/h) with hood 90 mm	185	55	22
Fuel consumption (l/h)	0.51	0.11	–
Average electrical power consumption (watt)	during operation	65	6
	while starting	≤ 100	
Closed-circuit power consumption	100 µA		
Rated voltage	12 volt		
Operating range			
Lower voltage limit: An undervoltage protector installed in the control box switches off the heater if the voltage limit is reached.	approx. 10.5 volt Undervoltage protection response time: 20 seconds ±1		
Upper voltage limit: An overvoltage protector (surge suppressor) installed in the control box switches off the heater if the voltage limit is reached.	approx. 16 volt Overvoltage protection response time: 20 seconds ±1		
Ambient temperature	Heater	during operation	–40 °C to +70 °C
		not in operation	–40 °C to +85 °C
	Metering pump	during operation	–40 °C to +50 °C
		not in operation	–40 °C to +125 °C
Hot air intake temperature	max. +40 °C		
Combustion air temperature	max. +50 °C		
Interference suppression	Suppression class 5 to EN 55025		
Degree of protection in accordance with ISO 20653	during operation	IP5k4k	
	not in operation	IP5k6k and IP5k9k	
Weight	approx. 4.5 kg		
Ventilation mode	possible		

 **Attention!**

Safety instructions for technical data!

Failure to comply with the technical data can result in malfunctions.

 **Note**

Provided no other values are given, the technical data provided is with the usual tolerances of ±10 % at rated voltage, 20 °C ambient temperature and reference altitude Esslingen.

3.4 Airtronic M2 B4L

Heater type	Airtronic		
Heater	Airtronic M2		
Version	B4L		
Heating medium	Air		
Fuel	Petrol – standard commercially available (DIN EN 228)		
For information on “Fuel quality” and “Fuel at low temperatures” see page 11.			
Control of the heat flow	Maximum	Minimum	Off
Heat flow (watt)	3800	1300	–
Hot air throughput without backpressure (kg/h) with hood 90 mm	180	85	24
Fuel consumption (l/h)	0.54	0.18	–
Average electrical power consumption (watt)	during operation	42	7
	while starting	≤ 100	
Closed-circuit power consumption	100 µA		
Rated voltage	12 volt		
Operating range			
Lower voltage limit:	approx. 10.5 volt		
An undervoltage protector installed in the control box switches off the heater if the voltage limit is reached.	Undervoltage protection response time: 20 seconds ±1		
Upper voltage limit:	approx. 16 volt		
An overvoltage protector (surge suppressor) installed in the control box switches off the heater if the voltage limit is reached.	Overvoltage protection response time: 20 seconds ±1		
Ambient temperature	Heater	during operation	–40 °C to +50 °C
		not in operation	–40 °C to +85 °C
	Metering pump	during operation	–40 °C to +50 °C
		not in operation	–40 °C to +125 °C
Hot air intake temperature	max. +40 °C		
Combustion air temperature	max. +50 °C		
Interference suppression	Suppression class 5 to EN 55025		
Degree of protection in accordance with ISO 20653	during operation	IP5k4k	
	not in operation	IP5k6k and IP5k9k	
Weight	approx. 4.5 kg		
Ventilation mode	possible		

Attention!
Safety instructions for technical data!

Failure to comply with the technical data can result in malfunctions.

Note

Provided no other values are given, the technical data provided is with the usual tolerances of ±10 % at rated voltage, 20 °C ambient temperature and reference altitude Esslingen.

3.5 Control values

3.5.1 Resistance values

Resistance values at 20 °C	12 volt	24 volt
Glow plug	0.42 Ω – 0.70 Ω	1.2 Ω – 2.0 Ω
Metering pump	9.5 Ω ±0.50 Ω	36.0 Ω ±1.8 Ω

Control unit resistance values	Left stop switch position	Right stop switch position
Mini controller (12 volt / 24 volt)	min. 1730 Ω max. 1780 Ω	min. 2120 Ω max. 2240 Ω

3.5.2 Exhaust value

CO₂ in the exhaust

in “Power” control stage: 7.5 – 12.5 % by vol.

Bacharach soot number: < 4

3.5.3 Checking the “external” temperature sensor

(Order No.: 25.1774.89.0300)

The “external” temperature sensor must be checked using a digital multimeter. Replace the temperature sensor if the resistance value is not the same as the curve in the diagram or the table of values.

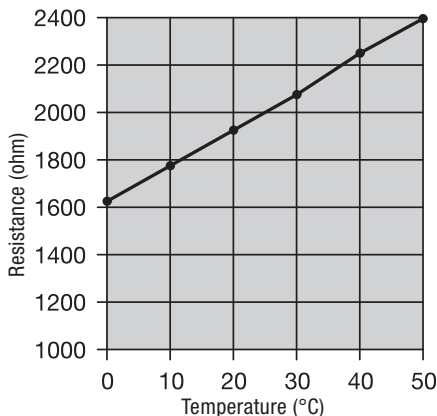

Table of values – “External” temperature sensor

Temperature °C	Resistance Ω	
	min.	max.
0	1600	1660
5	1670	1730
10	1745	1800
15	1820	1870
20	1895	1950
25	1970	2030
30	2050	2110
35	2130	2190
40	2210	2280
45	2295	2370

4 Troubleshooting

4.1 What to check first in case of faults

- Check
 - Fuel in the tank?
 - Fuel lines leaking? (Visual check)
 - Summer diesel in the fuel line?
 - Combustion air system or exhaust system damaged or blocked?
 - Hot air system blocked?
 - New generation control box installed?
 - Features:
 - > Control box cable loom wound with cable tape
- Electrical components
 - Cables, connections damaged?
 - Contacts corroded?
 - Fuses defective?
 - Incorrect wiring? (short circuits, interrupted / broken)
- Measure battery voltage
 - Battery voltage < 10.5 volt: the undervoltage protection of the 12 volt heater has triggered.
 - Battery voltage < 21.5 volt: the undervoltage protection of the 24 volt heater has triggered.
- Measure voltage supply (Terminal 30)
 - Disconnect the 10-pin connector XS10 / XB10 and measure the applied voltage in connector B1 between chamber 2 (br) and chamber 4 (rd).
 - If it differs from the battery voltage, check the fuses, the supply cables, the negative connection and the positive support point on the battery for voltage drop (corrosion / interruption).

4.2 Control box is locked

The control box is locked if the following faults occur:

- Unsuccessful start attempts
 - After 10 consecutive failed start attempts.
- Overheating
 - After 10-times shutdown on overheating.

4.3 Unlocking the control box

In case of locking due to too many overheating events, the control box can be unlocked by removing the heater fuse:

- Switch on heater.
- Remove heater fuse within 20 seconds.
- Re-insert the heater fuse after around 5 seconds.

i Note

The control box can also be unlocked using test equipment / a control unit. For the procedure and description for testing equipment and control units, see “Installation Instructions Plus – EasyStart/Altitude Kit / Special Functions and Diagnosis”.

4.4 Overview of the test equipment and control units suitable for diagnosis

The electronic control box can store up to 20 faults, which can be read out and displayed (10 active faults, 10 stored faults). The following test equipment and control units can be used to query the fault memory in the control box and if necessary, to delete the locking of the control box:

Test equipment	Order No.:
▪ EasyScan	22.1550.89.0000

The following control units can also be used:

Control units	Order No.:
▪ EasyStart Remote+	22.1000.34.1700
▪ Easy Start Pro	22.1000.35.2200
▪ EasyStart Web	22.1000.34.5100
▪ EasyStart Web	22.1000.34.7800

Note

- If the readout is made using a LIN control unit, only 1 active and 5 stored faults are displayed.
- Control units connected to the heater via the switch input S+ cannot be used for diagnosis.

4.5 Notes on heater diagnosis with control units

4.5.1 Easy Start Pro

Note

For details of how to read out the heat faults, see ES Pro installation instructions

4.5.2 EasyStart Web

Note

The heater faults are read out via the workshop access of the web application, see also PLUS installation instructions

4.5.3 EasyStart Remote+

- Connection via LIN interface

If faults occur while the heater is running, they are displayed with “Err” after the mobile unit is activated.

The current fault is displayed. The stored faults “F1” to “F5” can be enquired.

4.6 Flashing code display

4.6.1 Function display and error output via flashing code

Output of the operating display (combustion mode or output control):

→ LED lights up permanently

In case of error:

→ Output of the current error as a flashing code (see table)

	2s	4s	6s	8s	No.	Error
█	█	█	█	█	0	No fault / normal operation
█	█	█	█	█	1	Locking due to overheating
█	█	█	█	█	2	Overvoltage cut-off
█	█	█	█	█	3	Undervoltage cut-off
█	█	█	█	█	4	Glow plug is defective
█	█	█	█	█	5	Burner motor is defective
█	█	█	█	█	6	Invalid configuration
█	█	█	█	█	7	Safety time exceeded
█	█	█	█	█	8	Overheating
█	█	█	█	█	9	Metering pump is defective
█	█	█	█	█	10	Ext. Temperature sensor / setpoint transmitter is defective
█	█	█	█	█	11	Combination sensor is defective
█	█	█	█	█	12	Flame cutout
█	█	█	█	█	13	Too many exceedances of "safety time 1" ¹⁾
█	█	█	█	█	14	Control box defective
█	█	█	█	█	15	Other errors: EasyScan diagnosis necessary

1) Exceeding of the allowable number of starts

4.7 Fault code table

Fault code P000... for EasyScan and TP 7.1 (if connected via CAN) (...) for TP 7 (LIN)	Error description	Cause <ul style="list-style-type: none"> ▪ Remedial action
P000100 (071) P000101 (072) P000102 (073)	Overheating/air outlet sensor <ul style="list-style-type: none"> – Interruption – Short circuit – Short circuit to battery (+) 	<ul style="list-style-type: none"> ▪ Check overheating sensor. <ul style="list-style-type: none"> – Check cables for continuity, short circuit and damage. – Unplug connector -XB2, measure resistance between cable BU (chamber 1) and cable GN (chamber 2). – Measured values see page 27, in case of deviating values → renew lead harness of heater.
P000110 (087) P000111 (088) P000112 (089)	Water/air inlet error <ul style="list-style-type: none"> – Interruption – Short circuit – Short circuit to battery (+) <p>i Note! Fault code P000110 (087) and P000111 (088) are displayed only if</p> <ul style="list-style-type: none"> ▪ the heater is in operation ▪ Temperature reached at water outlet sensor at least 80 °C. 	<ul style="list-style-type: none"> ▪ Check the water inlet sensor. Check cables for continuity, short circuit and damage. <ul style="list-style-type: none"> – Unplug connector -XB2, measure resistance between cable BU (chamber 1) and cable GN (chamber 2). – Measured values see page 27, in case of deviating values → renew lead harness of heater.
P00010A (051)	Cold blowing <ul style="list-style-type: none"> – Timeout 	The combustion chamber has not cooled sufficiently for a restart. <ul style="list-style-type: none"> ▪ Check whether hot combustion air is drawn in. If not → check flame sensor, see Fault code P000120 (064) and Fault code P000121 (065).
P000114 (014)	Possible risk of overheating (implausible signal) <p>i Note! Fault code P000114 (014) is displayed only if</p> <ul style="list-style-type: none"> ▪ the heater is in operation ▪ Temperature reached at overheating sensor at least 80 °C. 	Temperature difference between the flame and overheating sensor is too large. <ul style="list-style-type: none"> ▪ For remedial action see Fault code P000115 (012). ▪ Check flame sensor. <ul style="list-style-type: none"> – Unplug connector -XB4, measure resistance between cable BU (chamber 5) and cable BU (chamber 6). – Measured values see page 27, in case of deviating values → renew lead harness of heater.
P000115 (012)	Overheating <ul style="list-style-type: none"> – Software threshold exceeded 	Temperature at overheating sensor >125 °C <ul style="list-style-type: none"> ▪ Check air throughput ▪ Check overheating sensor <ul style="list-style-type: none"> – Check cables for continuity, short circuit and damage. – Unplug connector -XB4, measure resistance between cable RD (chamber 9) and cable RD (chamber 10). – Measured values see page 27, in case of deviating values → renew lead harness of heater.
P000116 (017)	Overheating <ul style="list-style-type: none"> – Hardware threshold exceeded 	Temperature at overheating sensor >130 °C <ul style="list-style-type: none"> ▪ For remedial action see Fault code P000115 (012). ▪ Check overheating sensor. <ul style="list-style-type: none"> – Check cables for continuity, short circuit and damage. – Unplug connector -XB4, measure resistance between cable RD (chamber 9) and cable RD (chamber 10). – Measured values see page 27, in case of deviating values → renew lead harness of heater.

Fault code P000... for EasyScan and TP 7.1 (if con- nected via CAN) (...) for TP 7 (LIN)	Error description	Cause <ul style="list-style-type: none"> ▪ Remedial action
P00011A (015)	Operating lock-out – Too many overheating events detected	The control box is locked due to too frequent consecutive overheating (Fault code P000114 (014) , Fault code P000115 (012)). <ul style="list-style-type: none"> ▪ For remedial action see Fault code P000114 (014), Fault code P000115 (012). ▪ Unlock control box, see Chapter 4.3, p. 13.
P000120 (064) P000121 (065) P000122	Flame sensor – Interruption – Short circuit – Short circuit to battery (+)	<ul style="list-style-type: none"> ▪ Check flame sensor. <ul style="list-style-type: none"> – Check cable for continuity, short circuit and damage. – Unplug connector -XB2, measure resistance between cable BU (chamber 1) and cable GN (chamber 2). <ul style="list-style-type: none"> – Measured values see page 27, in case of deviating values → renew lead harness of heater. ▪ Further display Fault code P000120 (064) and Fault code P000121 (065) → replace control box, see Chapter 5.4.2, p. 23.
P000125 (057) P000126 (053) P000127 (054) P000128 (055) P000129 (056)	Flame cutout from start process Flame cutout within the control range 0% – 25% Flame cutout within the control range 25% – 50% Flame cutout within the control range 50% – 75% Flame cutout within the control range 75% – 100% i Note! In case of flame cutout during the start phase or in normal operation the heater is restarted (max. 3 times). If the restart was successful, the fault code display is deleted.	<ul style="list-style-type: none"> ▪ Check exhaust and combustion air system. ▪ Check fuel quantity and fuel supply, see Chapter 5.6, p. 34. ▪ Check flame sensor, see Fault code P000120 (064) and Fault code P000121 (065).
P00012A (052)	Safety time 1 – Exceedance	<ul style="list-style-type: none"> ▪ Check exhaust and combustion air system. ▪ Check fuel quantity and fuel supply, see Chapter 5.6, p. 34. ▪ Renew the fuel filter. ▪ Clean the fuel filter in the connection socket of the metering pump.
P00012B (050)	Operating lock-out, too many safety timeouts	Following three unsuccessful start attempts the control box is locked. <ul style="list-style-type: none"> ▪ Unlock control box, see Chapter 4.3, p. 13. ▪ Check fuel quantity and fuel supply, see Chapter 5.6, p. 34.

Fault code P000... for EasyScan and TP 7.1 (if connected via CAN) (...) for TP 7 (LIN)	Error description	Cause <ul style="list-style-type: none"> ▪ Remedial action
P000130 (060)	External air inlet temperature sensor (LEF2) <ul style="list-style-type: none"> – Interruption 	<ul style="list-style-type: none"> ▪ Test external air inlet sensor ▪ Disconnect the GYRD / BNWH plug-in connection of the external sensor and measure the resistance value, diagram and table of values see page 13, <ul style="list-style-type: none"> – if temperature sensor is ok, re-connect the GYRD / BNWH plug-in connection. ▪ Disconnect connector XS12/XB12 at the heater and measure the resistance value in connector housing XB12 between PIN 6 and PIN 12. If an interruption occurs, the ohmic value is $> 7175 \Omega / > 3 \text{ k}\Omega$. ▪ If resistance value is ok → replace control box.
P000131 (061) P000132	External air inlet temperature sensor (LEF2) <ul style="list-style-type: none"> – Short circuit – Short circuit to battery (+) 	<ul style="list-style-type: none"> ▪ Test external air inlet sensor ▪ Disconnect the GYRD / BNWH plug-in connection of the external temperature sensor and measure the resistance value, diagram and table of values see page 13, <ul style="list-style-type: none"> – if ok, re-connect the GYRD / BNWH plug-in connection. ▪ Disconnect connector XS12/XB12 at the heater and measure the resistance value in connector housing XB12 between PIN 6 and PIN 12. In case of short circuit, the ohmic value is $< 486 \Omega / < 800 \Omega$. ▪ If the error P000131 (061) continues to be displayed → replace control box.
P000143 (006)	Air pressure sensor <ul style="list-style-type: none"> – Implausible signal 	<ul style="list-style-type: none"> ▪ Delete error and try again. ▪ If error occurs again, replace control box.
P000200 (048) P000201 (047)	Metering pump <ul style="list-style-type: none"> – Interruption – Short circuit 	<ul style="list-style-type: none"> ▪ Check metering pump lead harness for continuity, short circuit and damage. <ul style="list-style-type: none"> – Lead harness ok → renew the metering pump.
P000202 (049)	Metering pump <ul style="list-style-type: none"> – Short circuit to battery (+) or transistor error 	<ul style="list-style-type: none"> ▪ Check cables for continuity, short circuit and damage. <ul style="list-style-type: none"> – Unplug the connector at the metering pump. ▪ Display Fault code P000200 (048) metering pump defective → replace metering pump.
P000210 (020) P000211 (021) P000212 (022)	Glow plug <ul style="list-style-type: none"> – Interruption – Short circuit – Short circuit to battery (+) or transistor error <p>⚠ Caution! Damage to unit in case of overvoltage Voltage $> 9.5 \text{ V}$ irreparably damages the glow plug. → Test function with max. 9.5 V.</p> <p>i Note Note the short-circuit withstand capability of the power pack.</p>	<ul style="list-style-type: none"> ▪ Check glow plug. <ul style="list-style-type: none"> – Check cables for continuity, short circuit and damage. – Unplug connector -XB4, unclip cable WH (chamber 3) and cable WH (chamber 4). – Apply $9.5 \text{ V} \pm 0.1 \text{ V}$ voltage to the glow plug and after 25 sec measure the current intensity. <ul style="list-style-type: none"> – Measured value 9.5 A (+1 / -1.5) the glow plug is ok – In case of deviating values → replace glow plug.
P000213 (019)	Glow plug <ul style="list-style-type: none"> – Ignition energy too low 	Glow plug energy input is too low. <ul style="list-style-type: none"> ▪ Check cables for continuity, short circuit and damage. ▪ Test glow plug, see Fault code P000210 (020) to Fault code P000212 (022).

Fault code P000... for EasyScan and TP 7.1 (if con- nected via CAN) (...) for TP 7 (LIN)	Error description	Cause <ul style="list-style-type: none"> ▪ Remedial action
P000220 (031) P000221 (032)	Electric motor – Interruption – Short circuit	<ul style="list-style-type: none"> ▪ Measure fan speed with EasyScan diagnostic tool, see EasyScan operating instructions.
P000223 (033)	Burner motor – Blocking	<p>Impeller blocked (frozen, soiled, sluggish, ...).</p> <ul style="list-style-type: none"> ▪ Remove blockage. <ul style="list-style-type: none"> – Check electric motor for smooth and easy running by turning the impeller manually. <p>i Note! In the case of the Airtronic D4L 24V, during running heating mode and simultaneous motor start and undervoltage of the vehicle battery, in exceptional cases, error message P000223 (033) can occur, although no valid faults exist.</p> <ul style="list-style-type: none"> ▪ Delete faults using EasyScan and acknowledge in the control unit on occurrence. <p>Further display Fault code P000300 (074)</p> <ul style="list-style-type: none"> ▪ Renew fan, see Chapter 5.4.10, p. 28.
P000260 P000261 P000262	Universal output – Interruption – Short circuit – Short circuit to battery (+) or transistor error	<p>Test universal output.</p> <ul style="list-style-type: none"> ▪ Test WHRD conductor for continuity, short circuit and damage. ▪ If cable ok → replace control box.
P000300 (074)	Overheating detection Metering pump hardware or cutout circuit defective	<ul style="list-style-type: none"> ▪ Test air outlet sensor. <ul style="list-style-type: none"> – Check cables for continuity, short circuit and damage. – Unplug connector XB4, measure resistance between cable RD (chamber 9) and cable RD (chamber 10). <ul style="list-style-type: none"> – Measured values see page 27, in case of deviating values → renew lead harness of heater. ▪ Further display Fault code P000300 (074) → replace lead harness of the heater. ▪ Unlock control box, see Chapter 4.3, p. 13.
P000301 (090) P000302 (090)	Watchdog reset Too many watchdog resets	<ul style="list-style-type: none"> ▪ Delete errors, the heater remains ready for operation. ▪ Replace control box, see Chapter 5.4.2, p. 23
P000303 (099)	Operating lockout: Too frequent output stage errors	<ul style="list-style-type: none"> ▪ Replace control box, see Chapter 5.4.2, p. 23
P000304 (091)	Too many resets (loose contact)	<ul style="list-style-type: none"> ▪ Replace control box, see Chapter 5.4.2, p. 23
P000305 (095)	Control box not calibrated	<ul style="list-style-type: none"> ▪ Replace control box, see Chapter 5.4.2, p. 23
P000306 (098)	Second cutout circuit is defective	<ul style="list-style-type: none"> ▪ Replace control box, see Chapter 5.4.2, p. 23
P000307 (081)	CAN communication error in control unit	
P00030A	CAN communication error	Delete error. Heater remains ready for operation.

Fault code P000... for EasyScan and TP 7.1 (if connected via CAN) (...) for TP 7 (LIN)	Error description	Cause <ul style="list-style-type: none"> ▪ Remedial action
P000310 (010) P000311 (010)	Control box cutout due to overvoltage Heater cutout due to overvoltage i Note! Heater is not functioning.	Overvoltage applied at the control box without interruption for at least 20 seconds. <ul style="list-style-type: none"> ▪ Unplug connector -XB1 at the heater. ▪ Start the vehicle engine. ▪ Measure voltage between cable RD (chamber 1) and cable BN (chamber 2). <ul style="list-style-type: none"> – Airtronic 12 volt – voltage > 16 V → check generator controller – Airtronic 24 volt – voltage > 32 V → check generator controller – Check the battery.
P000312 (011) P000313 (011)	Control box cutout due to undervoltage Heater cutout due to undervoltage i Note! Heater is not functioning.	Undervoltage applied at the control box without interruption for at least 20 seconds. <ul style="list-style-type: none"> ▪ Unplug connector -XB1 at the heater. ▪ Start the vehicle engine. ▪ Measure voltage between cable RD (chamber 1) and cable BN (chamber 2). <ul style="list-style-type: none"> – Airtronic 12 volt – voltage < 10 V → check generator controller – Airtronic 24 volt – voltage < 21 V → check generator controller – Check the fuses, the supply cables, the ground connections and the positive terminal post at the battery for voltage drop (corrosion).
P000330 (092)	ROM error	<ul style="list-style-type: none"> ▪ Replace control box, see Chapter 5.4.2, p. 23
P000331 (093)	RAM error	<ul style="list-style-type: none"> ▪ Replace control box, see Chapter 5.4.2, p. 23
P000332 (094)	NVMEM error (EEPROM, DataFlash)	<ul style="list-style-type: none"> ▪ Replace control box, see Chapter 5.4.2, p. 23
P000342	Invalid configuration	Check ADR coding.
P000394 – Short circuit	ADR button	<ul style="list-style-type: none"> ▪ Test ADR button. – Check the cables at GYRD / BNWH for continuity, short-circuit and damage. – If cables ok → replace control box.
P000440 (083)	Timeout, communication with control unit	<ul style="list-style-type: none"> ▪ Delete errors and disconnect heater from the power supply. ▪ If error occurs again → replace control unit.

5 Repair instructions

This chapter describes the permitted repair work on the heater.

Before starting the repair work, always dismantle the hot air intake hose and the hot air hose at the heater.

If necessary, remove the heater from the vehicle to carry out repair work.

Assembly of the heater is described from page 29.



Danger!

Risk of injury, burns and poisoning!

Ensure the following before carrying out any work on the heater:

- Switch off the heater and leave it to cool.
- Disconnect the battery.
- Do not operate the heater in enclosed spaces (garage / workshop).

Exception: Existing exhaust extraction available directly at the entry to the exhaust pipe.



Caution!

Damage to the unit

- Always renew the seals and O-rings of dismantled components.
- Check all components for damage and replace if necessary.
- Check plug-in contacts, plug-in connections and cables for corrosion and damage, and repair if necessary.
- Only use original Eberspächer spare parts.
- Operation and after running of the heater may only be stopped in an emergency (see “EMERGENCY STOP” on page 6) by interrupting the battery current (risk of heater overheating).



Note!

Thread-forming screws are used to fix the components in the factory. In case of repair the thread is already pre-cut by the initial installation.

Installation instructions

- Position screw by hand and screw in.
 - Always keep to the given tightening torque.
- When screwing for the second time also position by hand and do not cut a new thread.
- The screw is suitable for max. 6 installation attempts.



Note!

After completing all the work and installing the heater in the vehicle, carry out a functional check on the heater.

5.1 Special tool

5.1.1 Release tool

An AMP release tool is used to unlock plug-in contacts. This can be ordered directly from AMP.

- Junior power timer AMP Order No. 1-1579007-6
- Micro-timer AMP Order No. 0-0539960-1

5.2 Repair steps



Note!

Basically, in the repair steps it is assumed that a defective component is removed and a new or functioning old component is installed. The description of the repair therefore omits the name “new”.

Remove / install control box

- [Chapter 5.4.2, p. 23](#)
- [Chapter 5.5.10, p. 32](#)

Remove / install glow plug

- [Chapter 5.4.3, p. 24](#)
- [Chapter 5.5.6, p. 30](#)

Visual inspection of glow plug lining / install lining

- [Chapter 5.4.4, p. 25](#)
- [Chapter 5.5.2, p. 29](#)

Remove / install heater

- [Chapter 5.4.5, p. 25](#)
- [Chapter 5.5.14, p. 33](#)

Remove / install outlet hood

- [Chapter 5.4.6, p. 25](#)
- [Chapter 5.5.12, p. 32](#)

Remove / install bottom jacket shell

- [Chapter 5.4.7, p. 26](#)
- [Chapter 5.5.11, p. 32](#)

Remove / install combination sensor

- [Chapter 5.4.9, p. 26](#)
- [Chapter 5.5.5, p. 30](#)

Check combination sensor

- [Chapter 5.4.8, p. 26](#)

Remove / install fan

- [Chapter 5.4.10, p. 28](#)
- [Chapter 5.5.4, p. 30](#)

Remove / install combustion chamber

- [Chapter 5.4.11, p. 28](#)
- [Chapter 5.5.3, p. 29](#)

Remove / install heat exchanger

- [Chapter 5.4.12, p. 28](#)
- [Chapter 5.5.1, p. 29](#)

5.3 Exploded drawing of heater

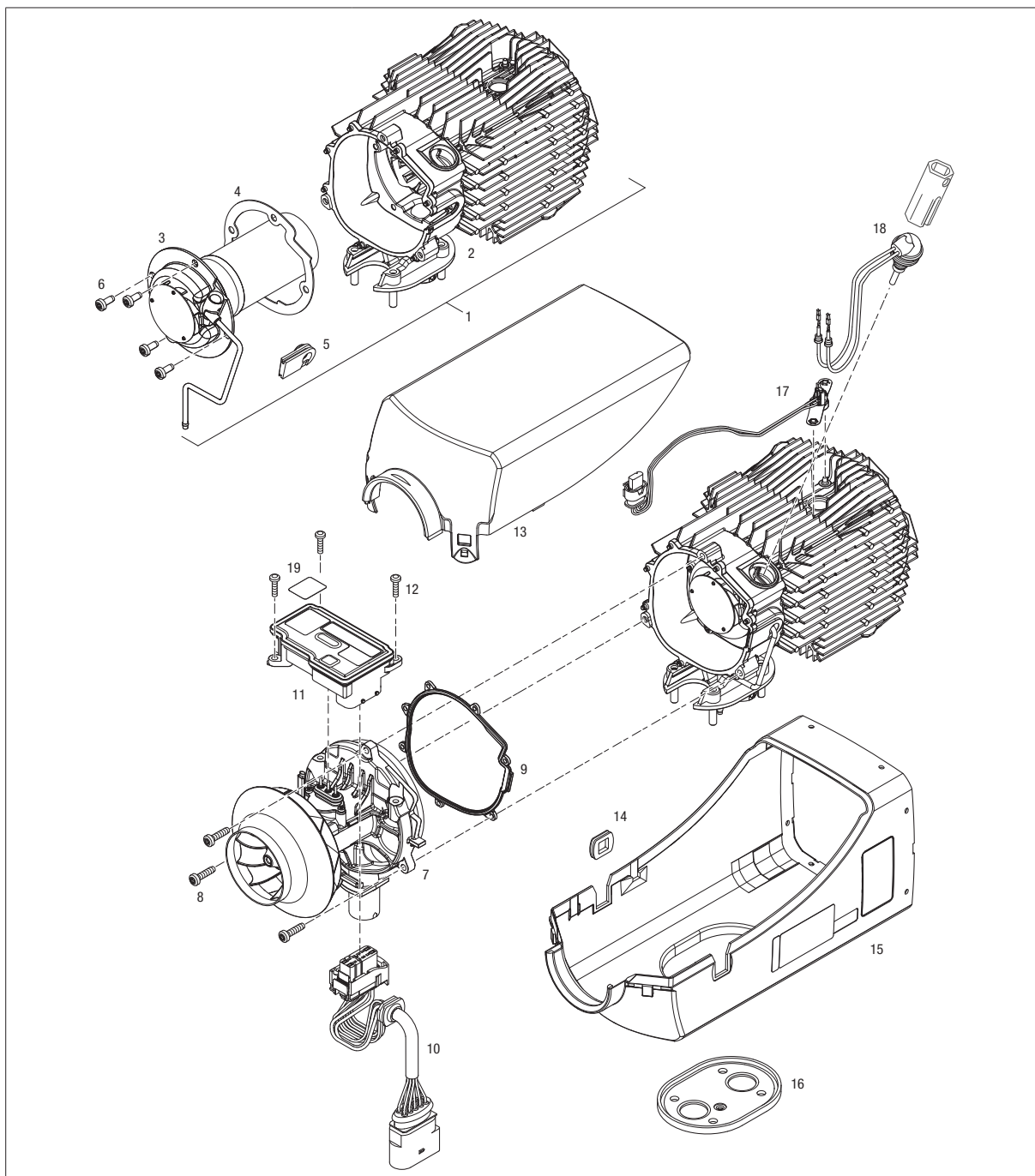

- | | | |
|--|------------------------------|---|
| 1 Heat exchanger incl. combustion chamber | 8 Fan fixing screws | 15 Jacket shell, bottom |
| 2 Heat exchanger | 9 Fan / heat exchanger seal | 16 Flange seal |
| 3 Combustion chamber | 10 Cable harness heater | 17 Combination sensor, overheating / flame sensor |
| 4 Combustion chamber / heat exchanger seal | 11 Control box | 18 Glow plug incl. installation tool |
| 5 Rubber grommet | 12 Control box fixing screws | 19 Control box sign |
| 6 Combustion changer fixing screws | 13 Jacket shell, top | |
| 7 Fan | 14 Rubber grommet | |

5.4 Dismantle the heater

i Note!

- Before starting the repair work, dismantle the hot air intake hose at the heater.
- The repair step 5.4.1 must be carried out for all repair work.
- Before removing the heater (step), dismantle the hot air hose from the outlet hood.

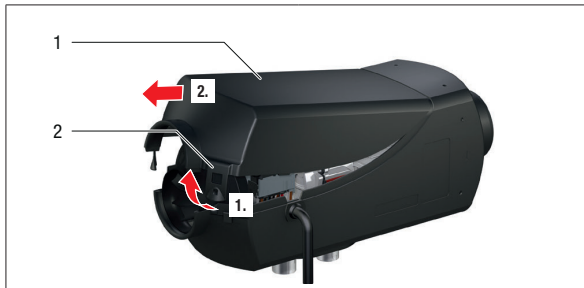

- 1 Jacket shell, top
2 Latch fastener

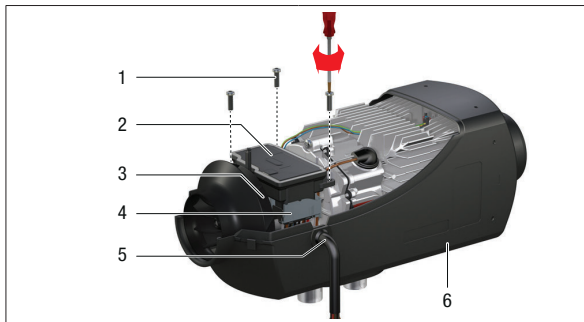

- 1 Fixing screws M4 × 16 (Torx) 4 Connector, control box
2 Control box 5 Lead harness
3 Fan motor 6 Jacket shell, bottom

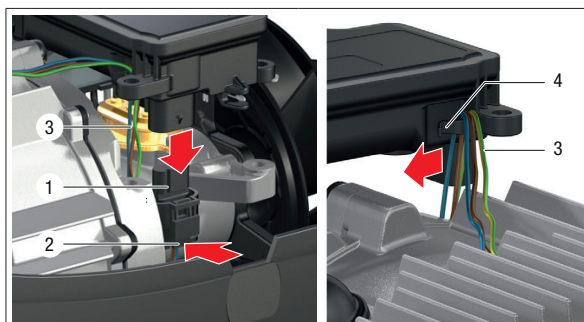

- 1 3-pin connector, combination sensor 3 Connecting leads
2 Connector lock 4 Cable routing

5.4.1 Removing the upper jacket shell

- Unlock both latch fasteners, lift the upper jacket shell and pull off in the direction of the arrow.

Next possible repair step:

Remove control box, see step 5.4.2

5.4.2 Removing the control box

- Unscrew 3 fixing screws of the control box [1].
- Pull the control box [2] off the fan motor [3].
- Pull lead harness [5] with grommet out of the lower jacket shell [6].

i Note!

Please note that after replacing the control box, all existing codings, e.g. for ADR mode, etc. must be restored.

Disconnect the combination sensor connector at the control box

- Press the connector lock [2] on the combination sensor connector [1] to unlock it.
- Disconnect the connector at the control box.
- Pull the connection cables [3] out of the cable routing [4] in the direction of the arrow.

Next possible repair steps:

- Test combination sensor, see step 5.4.8
- Remove combination sensor, see step 5.4.9

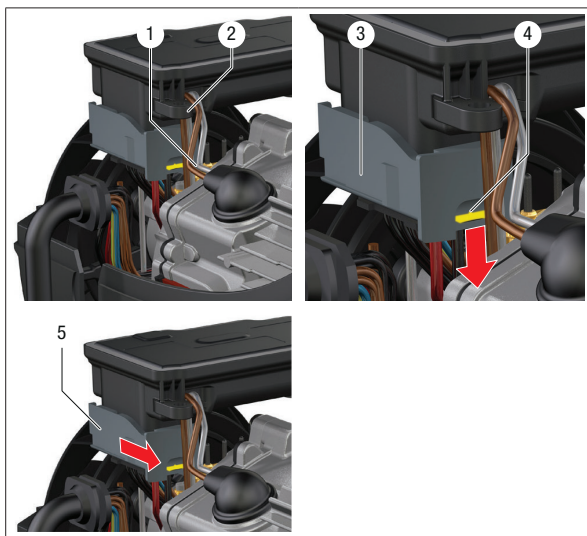

- | | |
|--------------------------------|------------------------|
| 1 Connection cables, glow plug | 4 Fuse, yellow |
| 2 Cable routing | 5 Connector part, grey |
| 3 Connector, control box | |

Removing the control box connector

i Note!

The control box connector is equipped with a special installation and locking function and cannot be simply pulled off the control box.

- Pull the glow plug connection cables [1] out of the cable routing [2].
- At the control box connector [3], push down the yellow lock [4] to unlock.
- Push the grey part of the connector [5] in the direction of the yellow lock until the connector releases itself from the control box.

The control box can be replaced.

Next possible repair step:

Remove glow plug, see step 5.4.3

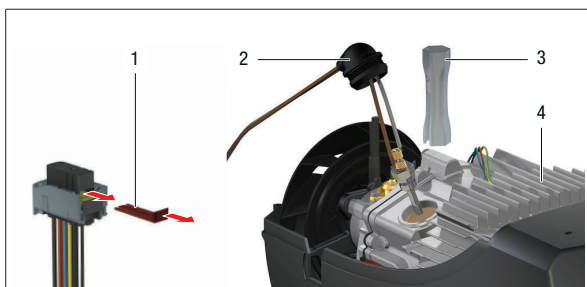

- | | |
|-----------------------|--------------------------------|
| 1 Pin protection, red | 3 Special socket spanner AF 12 |
| 2 Rubber grommet | |

5.4.3 Removing the glow plug

To replace the glow plug, unpin the connection cables from the control box connector.

i Note!

It is not necessary to unpin from the control box connector for the mere visual inspection of the glow plug.

- Carry out step 5.4.1 and step 5.4.2.
- At the control box connector, completely pull out the red pin protection [1].
- Use the AMP tool to unpin the glow plug connection cables at the control box connector from chamber 1 (BN) and chamber 7 (WH).

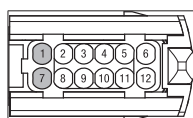

Connector shown from the cable inlet side.

- Pull off the rubber grommet [2] at the heat exchanger [4] and use special socket spanner AF 12 [3] to unscrew the glow plug.

i Note!

If the special socket spanner is not to hand or if the glow plug cannot be undone using the special socket spanner, remove the fan, see step 5.4.10. The glow plug is then accessible via the heat exchanger and can be unscrewed from the combustion chamber using an open-end spanner AF12.

Next possible repair steps:

- Visual inspection of glow plug lining, see step 5.4.4
- Install glow plug, see step 5.5.6

5.4.4 Visual inspection of glow plug lining

- Carry out step 5.4.1 to step 5.4.3.
- After removing the glow plug, check the lining in the socket for dirt.
 - Normal soiling of the surface: Use suitable agents to clean lining.
 - Heavy soiling of the surface: Replace glow plug lining, see step 5.5.2

i Note!

A highly soiled lining can only be removed destructively. On removing, ensure that no dirt or parts of the braiding fall into and block the fuel line. After removing the lining, clean the glow plug sockets.

Next possible repair step:

Install glow plug, see step 5.5.6

5.4.5 Removing the heater

The heater must be removed from the vehicle for steps 5.4.6 to 5.4.3.

- Remove fuel connection.
- Remove combustion air hose.
- Remove exhaust pipe.
- Unscrew the fixing screws at the unit flange.
- Undo the clamp on the outlet hood, pull off the hot air hose and remove the heater from the vehicle.

i Note!

If there is sufficient space around the heater in the place of installation, the outlet hood can also be removed without dismantling the hot air hose from the lower jacket shell, see step 5.4.6

5.4.6 Removing the outlet hood

- Carry out step 5.4.1 and step 5.4.5.
- 1. Insert the flathead screwdriver [1] into the recess [2] of the jacket shell [3].
- 2. Use the flathead screwdriver to bend up the jacket shell in the direction of the arrow until the snap connectors [4] release.
- Release the outlet hood, with or without hot air hose, from the lower jacket shell.

Next possible repair step:

Remove lower jacket shell, see step 5.4.7

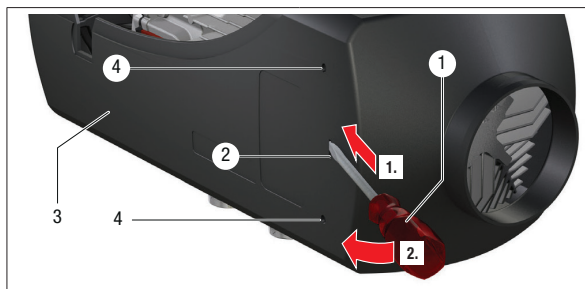

- | | |
|------------------------------|------------------------|
| 1 Flathead screwdriver | 3 Jacket shell, bottom |
| 2 Recess in the jacket shell | 4 Snap connector |

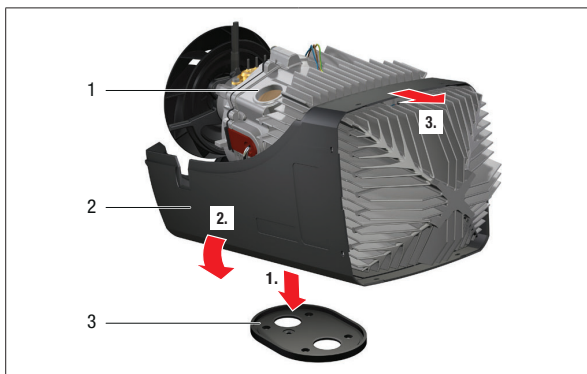

1 Heater 3 Flange seal
2 Jacket shell, bottom

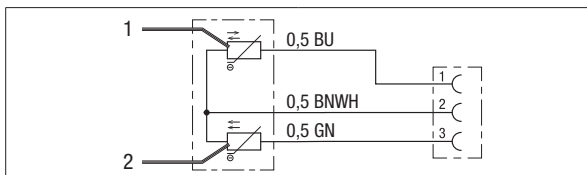

1 NTC overheating sensor 50 kΩ
2 PT 1000 flame sensor

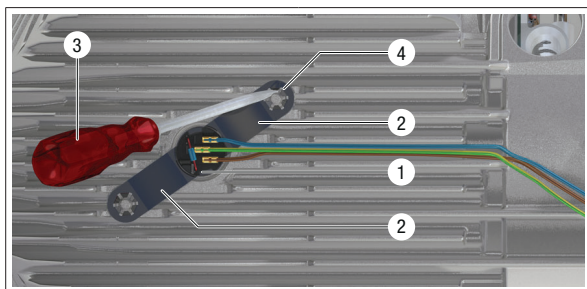

1 Combination sensor 3 Flathead screwdriver
2 Fastening tabs 4 Claws

5.4.7 Removing lower jacket shell

- Carry out step 5.4.1 and step 5.4.6.
- Hold onto the heater [1] and lower jacket shell [2]
- 1. Pull off flange seal [3].
- 2. Fold down the jacket shell.
- 3. Remove the jacket shell from the heater in the direction of the arrow and place to the side.

Next possible repair steps:

- Remove combination sensor, see step .
- Remove fan, see step 5.4.10

5.4.8 Testing the combination sensor

For the test with a digital multimeter, remove the combination sensor, see step 5.4.9.

Replace the combination sensor if the resistance values are not the same as the curves in the diagram or the table of values.

i Note!

Note the maximum temperature 320 °C for the test.

5.4.9 Removing the combination sensor

- Carry out step 5.4.1 to step 5.4.3 as well as step 5.4.5 to step 5.4.7.
- Insert a flathead screwdriver [3] (2 mm wide blade) between two claws [4] on both fixing tabs [2] of the defective combination sensor [1] and bend at least two claws per tab upwards.
- Remove defective combination sensor.

Next possible repair steps:

- Install combination sensor, see step 5.5.5
- Remove fan, see step 5.4.10

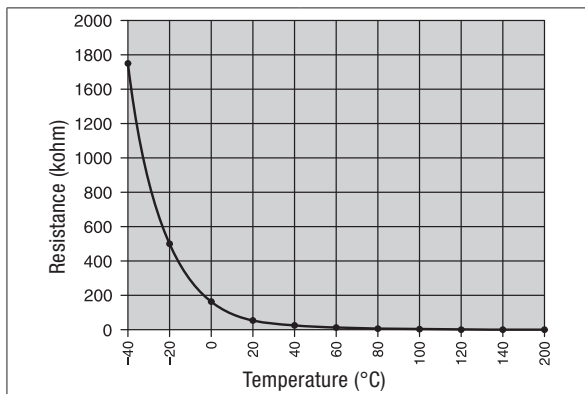

Testing the overheating sensor
Carry out step 5.4.1 to step 5.4.9.

To test the overheating sensor, measure the resistance in chambers 1 and 3 in connector -XS2.

Table of overheating sensor values

Temperature °C	Resistance kΩ	
	min.	max.
-40	1597.00	1913.00
-20	458.80	533.40
0	154.70	175.50
20	59.30	65.84
40	25.02	28.04
60	11.56	13.16
80	5.782	6.678
100	3.095	3.623
120	1.757	2.081
140	1.050	1.256
160	0.655	0.792
180	0.425	0.519
200	0.286	0.351

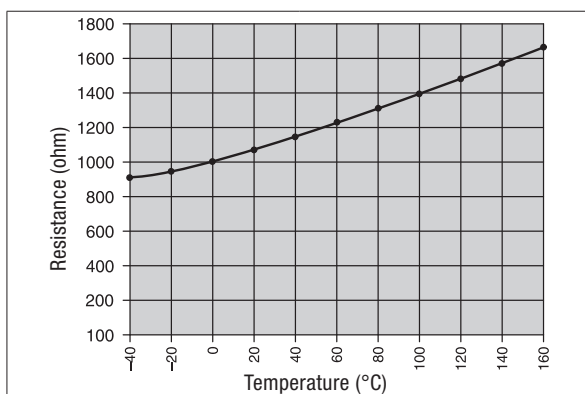

Check flame sensor

To test the flame sensor, measure the resistance in chambers 1 and 2 in connector -XS2.

Table of flame sensor values

Temperature °C	Setpoint	Resistance Ω	
		min.	max.
-40	843	826	860
-20	622	803	940
0	1000	980	1020
20	1078	1056	1100
40	1155	1132	1179.5
60	1232	1208	1257
80	1309	1283	1335
100	1385	1357	1413
120	1461	1432	1490
140	1536	1505	1567
160	1611	1578	1643

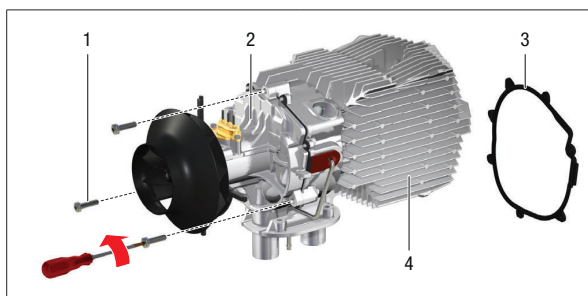

- | | | | |
|---|------------------------------|---|----------------|
| 1 | Fixing screws M5 × 20 (Torx) | 3 | Seal |
| 2 | Fan | 4 | Heat exchanger |

5.4.10 Removing the fan

i Note!

- A defective fan cannot be repaired. Replace the complete fan.
- The combustion air impeller is a sensitive, high-precision moulded component. Therefore, never place the fan on the combustion air impeller when dismantling / installing or expose the impeller to mechanical loads. Put the fan down to the side only.

- Carry out step 5.4.1 to step 5.4.3 as well as step 5.4.5 to step 5.4.7 and step 5.4.10.
- Unscrew the fixing screws [1] of the fan [2] at the heat exchanger [4].
- Remove the fan [2] and seal [3] from the heat exchanger. Dispose of seal according to regulations.

Next possible repair step:

Remove combustion chamber, see step 5.4.11

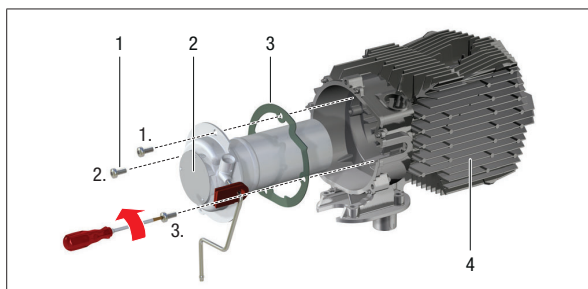

- | | |
|---|------------------------------|
| 1 | Fixing screws M5 × 12 (Torx) |
| 2 | Combustion chamber |
| 3 | Seal |
| 4 | Heat exchanger |

5.4.11 Removing the combustion chamber

- Carry out step 5.4.1 to step 5.4.3 as well as step 5.4.5 to step 5.4.10.
- Unscrew fixing screws [1] of the combustion chamber [2] at the heat exchanger [4].
- Pull the combustion chamber with fuel connection and grommet out of the heat exchanger.
- Remove the seal [3] of the combustion chamber – heat exchanger and dispose of according to the regulations.

i Note!

The combustion chamber is fixed with three screws in the Airtronic S2 heater and with four screws in the Airtronic M2 heater.

5.4.12 Removing the heat exchanger

To remove or replace the heat exchanger, carry out the steps

“5.4.1 Removing upper jacket shell” to “5.4.3 Removing the glow plug”,

“5.4.5 Removing the heater” to “5.4.9 Removing the combination sensor” as well as

“5.4.10 Removing the fan” and “5.4.11 Removing the combustion chamber”.

5.5 Assembling the heater

i Note!

Damage to unit caused by third party, damaged or deformed components

Installing third party, damaged or deformed components has a negative effect on the function of the heater.

- Replace damaged or deformed components.
- Use original Eberspächer spare parts only, see spare parts list.
- Use all the components included in spare parts kits.
- Always renew the heat exchanger after a heater operating period of 10 years.
- Always renew the seal between the combustion chamber and heat exchanger.

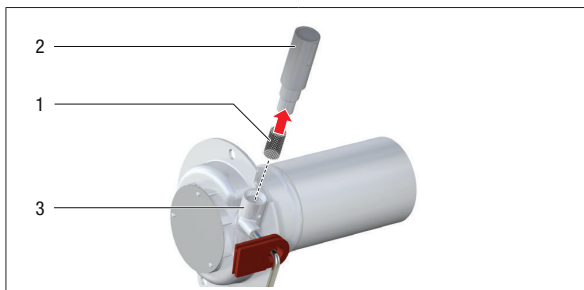

- 1 Lining
- 2 Installation tool
- 3 Glow plug socket

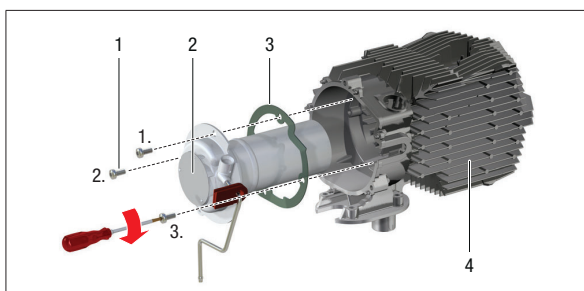

- 1 Fixing screws M5 × 12 (Torx)
- 2 Combustion chamber
- 3 Seal
- 4 Heat exchanger

5.5.1 Installing the heat exchanger

Before installing a used heat exchanger, check it for wear, damage or deformations.

Check a new heat exchanger for transport or material damage.

5.5.2 Installing the glow plug lining

- Push the lining [1] onto the installation tool [2] so that the lining and installation tool markings match.
- Insert the lining carefully into the glow plug socket [3] until it stops; at the same time, check for correct positioning.

i Note!

The installation tool is enclosed with the lining spare part.

Next possible repair step:

Install combustion chamber, see step 5.5.3

5.5.3 Installing the combustion chamber

i Note!

The heat exchanger is a component subjected to high thermal loads. Before installing the used heat exchanger, check for wear and deformation and replace if necessary.

- Clean the sealing surfaces of the heat exchanger [4] and combustion chamber [3] to remove possible seal residues.
- Insert new seal [3] into heat exchanger.
- Insert the combustion chamber [2] with fuel connection and grommet into the heat exchanger.
- Screw in the fixing screws [1] and tighten in the described order, tightening torque $5^{\pm 0,5}$ Nm.

i Note!

The combustion chamber is fixed with three screws in the Airtronic S2 heater and with four screws in the Airtronic M2 heater.

Next possible repair step:

Install fan, see step 5.5.4

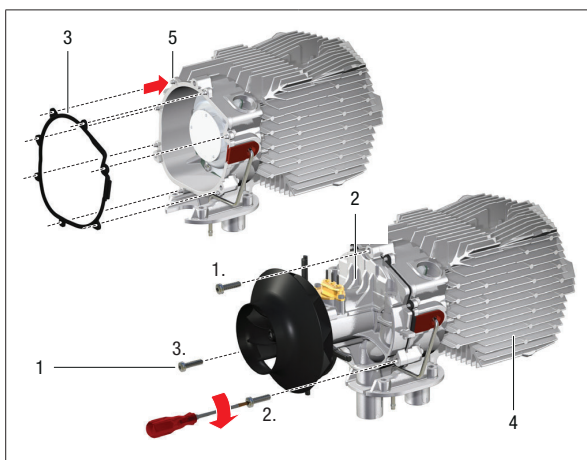

- | | |
|--------------------------------|------------------|
| 1 Fixing screws M5 × 20 (Torx) | 3 Fixing screws |
| 2 Fan | 4 Heat exchanger |
| | 5 Locating pin |

5.5.4 Installing the fan

- If applicable, carry out step 5.5.3 first
- Put on seal [3]. Push the tabs of the seal onto the locating pin [5] of the heat exchanger [4].
- Fix the fan [2] using the fixing screws [1] and tighten in the given order. Tightening torque 4 ± 0.5 Nm.

i Note!

The combustion air impeller is a sensitive, high-precision moulded component. Therefore, never place the fan on the combustion air impeller when dismantling / installing or expose the impeller to mechanical loads. Put the fan down to the side only.

Next possible repair steps:

- Install combination sensor, see step 5.5.5
- Install glow plug, see step 5.5.6

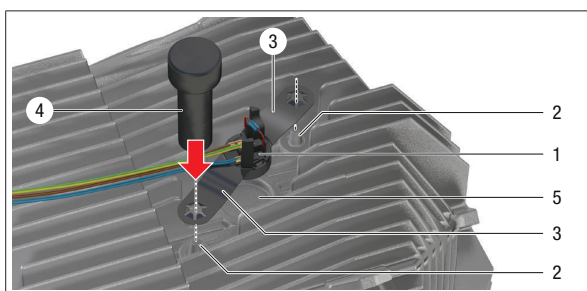

- | | |
|----------------------------------|--------------------|
| 1 Combination sensor | 4 Auxiliary tool |
| 2 Fixing bolt | 5 Retaining recess |
| 3 Combination sensor fixing tabs | |

5.5.5 Installing the combination sensor

- Manually premount the combination sensor [1] on the locating pin [2].
- Use an auxiliary tool [4] to press the combination sensor fixing tabs [3] onto the fixing bolt until they stop.
- Check for correct fit of the sensor in the retaining recess [5].

Next possible repair steps:

- Connect combination sensor, see step 5.5.9
- Install lower jacket shell, see step 5.5.11

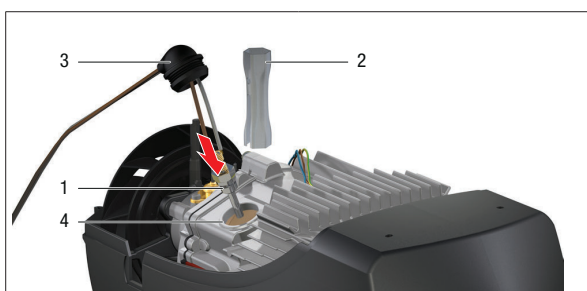

- | | |
|--------------------------|------------------|
| 1 Glow plug | 3 Rubber grommet |
| 2 Special socket spanner | 4 Glow plug hole |

5.5.6 Install glow plug

- Carry out step 5.5.2 to step 5.5.4.
- Insert glow plug [1] into the sockets and screw in by hand.
- Use special socket spanner [2] to tighten glow plug; tightening torque 6 ± 0.5 Nm.

i Note!

The special socket spanner AF 12 is enclosed with the glow plug spare part.

- Insert the rubber grommet [3] into the glow plug hole [4] in the heat exchanger.

⚠ Caution!

Personal injuries and damage to the unit due to leaks

Incorrect installation of the rubber grommet leads to leaks and can result in personal injuries as well as malfunction or damage to the heater. Insert the rubber grommet exactly into the glow plug hole in the heat exchanger.

Next possible repair step:

- Connect glow plug, see step 5.5.7

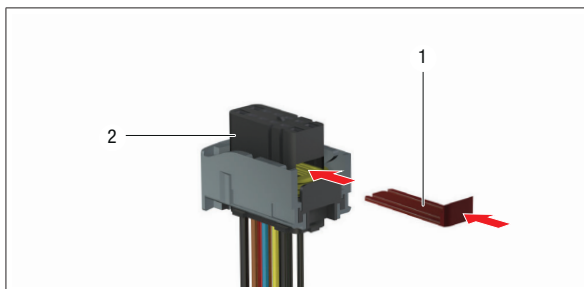

- 1 Pin protection, red
- 2 Connector, control box

5.5.7 Connecting the glow plug

- Pin the connection cables of the glow plug in chamber 1 (BN) and chamber 7 (WH) of the control box connector.

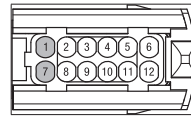

Connector shown from the cable inlet side.

- Completely push in the pin protection [1] on the control box connector [2].

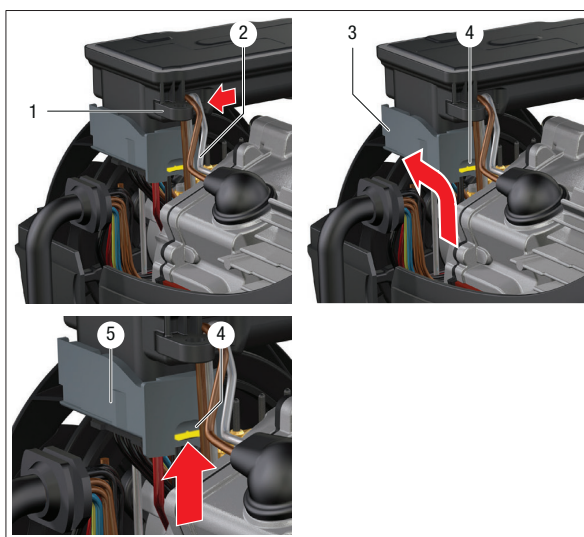

- 1 Connection cables, glow plug
- 2 Cable routing, left
- 3 Connector, control box
- 4 Connector lock, yellow
- 5 Connector part, grey

5.5.8 Connecting the lead harness

- Carry out step 5.5.7
- Pull in the connection cables of the glow plug [2] from the inside to the outside in the left-hand cable routing [1] at the control box. Ensure that the cables coming from the glow plug are fed through from the top down.
- Plug the control box connector [3] into the socket of the control box. The yellow connector lock [4] points towards the heat exchanger.
- The side lobes grip into the recesses in the grey part of the connector.
- Press the connector into the control box. The grey part of the connector [5] slides in the direction of the impeller by itself. Completely push in the connector part and push the yellow connector lock [4] upwards.

Next possible repair step:

Connect combination sensor, see step 5.5.9

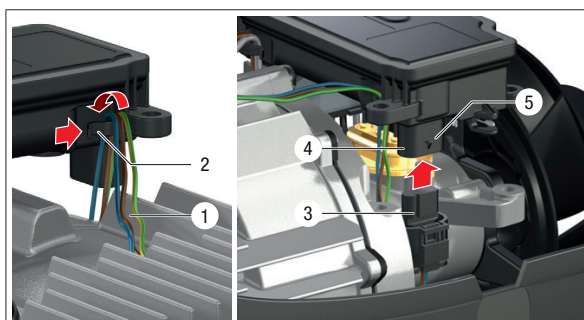

- 1 Connecting leads
- 2 Cable routing
- 3 Combination sensor connector
- 4 Bush
- 5 Snap lock

5.5.9 Connecting the combination sensor

- Lay the combination sensor connection cables to the control box between the fins of the heat exchanger so that no cables are crushed.
- Pull in the connection cables [1] from the inside to the outside in the right-hand cable routing [2] at the control box. Ensure that the cables coming from the combination sensor are fed through from the top down.
- Plug the combination sensor connector [3] into the anti-twist socket [4] on the underside of the control box. The connector sits precisely, if the snap lock [5] audibly latches into position.

Next possible repair step:

Install control box, see step 5.5.10

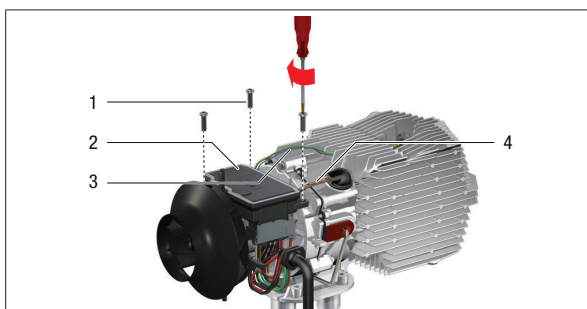

- 1 Fixing screws M4 × 16 (Torx)
- 2 Control box
- 3 Combination sensor connection cables
- 4 Connection cables, glow plug

5.5.10 Installing the control box

- Position the control box [2] on the contact pins of the fan motor and fasten using fixing screws [1].
- Pull the connection cables of the combination sensor [3] and glow plug [4] downwards to prevent crushing of the cables.

Next possible repair step:

Install lower jacket shell, see step 5.5.11

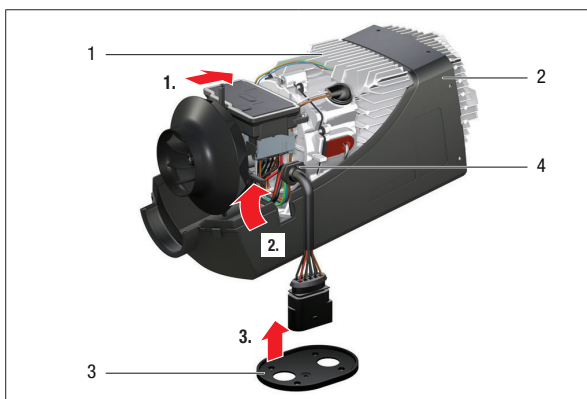

- 1 Heater
- 2 Jacket shell, bottom
- 3 Flange seal
- 4 Cable harness grommet

5.5.11 Mounting the lower jacket shell

- 1. Insert the heater [1] into the lower jacket shell [2].
- 2. Swing up the lower jacket shell.
- 3. Prefix with the flange seal [3].
- Depending on the connection situation in the vehicle, insert the cable harness grommet [4] into the right or left-hand recess of the lower jacket shell.

Next possible repair step:

Mount upper jacket shell, see step 5.5.13

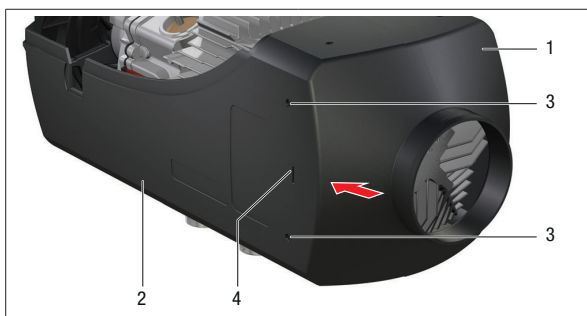

- 1 Outlet hood
- 2 Jacket shell, bottom
- 3 Snap connector
- 4 Recess

5.5.12 Installing the outlet hood

- 1. Position the outlet hood [1], with or without hot air hose, on the heat exchanger side of the lower jacket shell [2]. The pins of the snap connector [3] must be positioned on the jacket side with the recess [4].
- 2. Press the outlet hood into the lower jacket shell until the snap connectors latch into position.

Next possible repair step:

Install upper jacket shell, see step 5.5.13

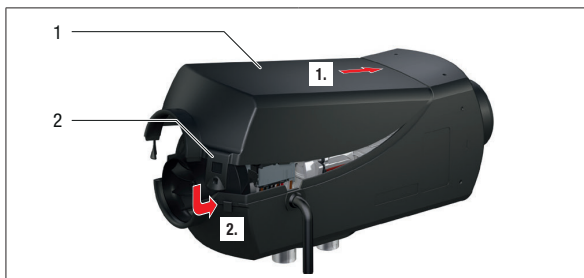

- 1 Jacket shell, top
- 2 Latch fastener

5.5.13 Mounting the upper jacket shell

- 1. Insert the jacket shell and fold down.
- 2. Press together the jacket shells until the two latch fasteners snap into position.
- Check the hot air impeller for free running.
- The heater is ready for installation.

Next possible repair step:

Install the heater, see step 5.5.14

5.5.14 Installing the heater

- Use the fixing screws to screw the heater onto the vehicle.
- Make the fuel connection.
- Attach the combustion air hose.
- Attach the exhaust pipe.
- Position the outlet hood with hot air hose on the heater and press into the jacket shell, until the fastening lobes of the hood latch into the jacket shell.
- Connect the heater cable harness to the vehicle's cable harness.
- Perform functional test (see Page 40).

5.6 Checking the fuel supply

Before measuring the fuel quantity, check the following points in the fuel supply.

- If necessary, check the strainer in the metering pump.
- Check the laying of the fuel pipes.
- Check fuel pipes for leaks.
- Check and tighten the hose connections.
- Is the fuel removal installed according to the details in the technical description?

5.6.1 Manual measurement of the fuel quantity

Preparation

- Remove the fuel pipe at the heater and discharge the fuel into a measuring cylinder (volume 25 cm³).
- Switch on the heater, if the fuel is uniformly pumped (begins approx. 60 sec after being switched on), the fuel pipe is full and vented.
- Switch off the heater, as otherwise a start repeat is performed and fuel is pumped again.
- Empty the measuring cylinder.

i Note!

- For precise fuel measurement, at least 11 / 22 volt or maximum 13 / 26 volt should be applied to the control box during the measurement.

Measurement

- Switch on heater – the fuel begins to be pumped approx. 60 sec after switching on the heater.
- During the measurement, hold the measuring cylinder at the level of the glow plug.

Airtronic S2 heater

- After 90 seconds the pumping of the fuel is switched off automatically.

Airtronic M2 heater

- After 105 seconds the pumping of the fuel is switched off automatically.

i Note

Switch off heater!

Important, as otherwise a start repeat is performed and fuel is pumped again.

- Read off the quantity of fuel in the measuring cylinder. If the measured quantity of fuel lies outside the values listed in the table, the metering pump must be replaced.

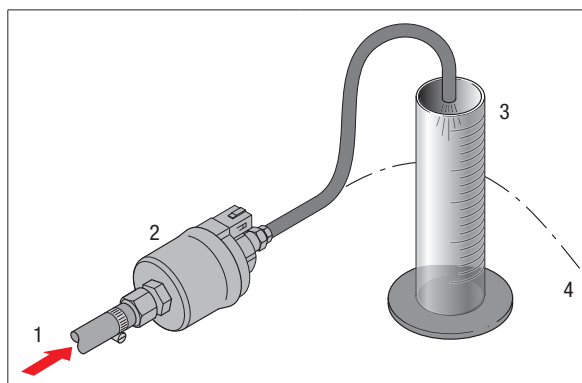

- 1 from the fuel tank 3 Measuring cylinder (size 10 ml)
 2 Metering pump (example) 4 to the heater

5.6.2 Measuring the fuel quantity with EasyScan

Preparation

- Pull off the fuel pipe at the heater and discharge the fuel into a measuring cylinder (volume > 25 cm³).
- Make the connection between the heater and EasyScan diagnostic interface VCI. To do this, connect the EasyScan to the diagnostics connector of the cable harness.
- Start the EasyScan diagnostic software
- In the "Diagnosis" menu, open the [Component activation] tab.
- Call up the [External components] submenu.
- Enter this test parameter in the [Metering pump] menu:
 - Frequency: 7 Hz
 - Duration: 60 seconds
- Press the [Start metering pump] button to start the measurement.
- Wait until the measurement process has ended, then read off the pumped quantity of fuel in the measuring centre.

If the measured quantity of fuel lies outside the values listed in the table, the metering pump must be replaced.

Table of values – fuel quantity

Heater type	Airtronic 2		
	S2 (D 2 L)	M2 (D 4 L)	M2 (B 4 L)
Delivery period in sec.	60		
Fuel quantity, nominal [ml]	8.7		8.1
Fuel quantity - max. [ml]	9.5		8.9
Fuel quantity - min [ml]	7.9		7.3
Delivery period in sec.	90		
Fuel quantity, nominal [ml]	13.1		12.2
Fuel quantity - max. [ml]	14.4		13.4
Fuel quantity - min [ml]	11.8		10.9
Delivery period in sec.	105		
Fuel quantity, nominal [ml]	15.3		14.2
Fuel quantity - max. [ml]	16.8		15.6
Fuel quantity - min [ml]	13.7		12.8

6 Electrics

6.1 Heater wiring

The electronic control box is integrated in the heater, which makes wiring during installation much easier.

Caution

Safety instructions

The heater is to be connected up electrically according to the EMC directives.

EMC can be affected if the heater is not connected up correctly. For this reason, comply with the following instructions:

- Ensure that the insulation of electrical cables is not damaged.
Avoid: Chafing, kinking, jamming or exposure to heat.
- In waterproof connectors, seal any connector chambers not in use with filler plugs to ensure they are dirt-proof and water-proof.
- Electrical connections and ground connections must be free of corrosion and firmly connected.
- Lubricate connections and ground connections outside the heater interior with contact grease.

Note

Comply with the following when wiring the heater and the control unit:

- Electrical leads, switch and control boxes must be positioned in the vehicle so that they can function perfectly under normal operating conditions without impairment (e.g. due to heat exposure, moisture, etc.).
- The following cable cross-sections are to be used between the battery and heater. This ensures that the max. permissible voltage drop in the cables does not exceed 0.5 V for 12 V or 1 V for 24 V rated voltage.
Cable cross-sections for a cable length (plus cable + minus cable) of:
 - up to 5 m = cable cross-section 4 mm²
 - from 5 m to 8 m = cable cross-section 6 mm²
- If the positive cable is to be connected to the fuse box (e.g. terminal 30), the vehicle's cable from the battery to the fuse box must also be included in the calculation for the total cable length and re-dimensioned if necessary.
- Insulate unused cable ends.

6.2 Parts list for the Airtronic S2 and Airtronic M2 circuit diagrams

- A1 Airtronic Ax2 control box
- A30 Fuse holder, 3 pin
- B1 Air inlet sensor, internal (LEF1)
- B6 Flame and air outlet sensor
- R1 Terminating resistor I
- R2 Terminating resistor II
- R3 Terminating resistor, stub line

- F1 Heater fuse: 12 V = 20 A / 24 V = 10 A
- HG Heater
- R1 Glow plug
- Y1 Fuel metering pump
- p Switch output
- XB6/1 Bush housing, tester
- XS6/1 Mating connector with terminating resistor

Optional

- b Activation of vehicle blower and / or separate fresh air fan

Note

- The plus signal is applied in "Low" control stage only (PIN 16, plus signal for relay, I_{max} = 200 mA).

- d to the ADR acknowledgement button, see on page 26
- n Generator input D+
- o Secondary drive input NA+

Note

- It must be ensured that if the battery isolating switch is pressed due to EMERGENCY STOP, all the heater's electric circuits are disconnected from the battery immediately (without any consideration of the heater's status).
- If the battery isolating switch is pressed to disconnect the battery from all electric circuits, the heater must be switched off first and if applicable you must wait until the heater's afterrun has finished.

- a to the heater
- c1 to the control unit CAN
- c2 to the control unit LIN / S+
- g to the external temperature sensor / mini controller
- x insulate and tie back any cables that are not needed

Note

Circuit diagram for Airtronic S2 / Airtronic M2 from page 42.

Circuit diagrams for control units, e.g. EasyStart Remote+ etc., see from page 42.

Cable colours

bk = black	og = orange
bn = brown	rd = red
bu = blue	vt = violet
gn = green	wh = white
gy = grey	ye = yellow

6.3 Circuit diagrams for Airtronic

6.3.1 Heater

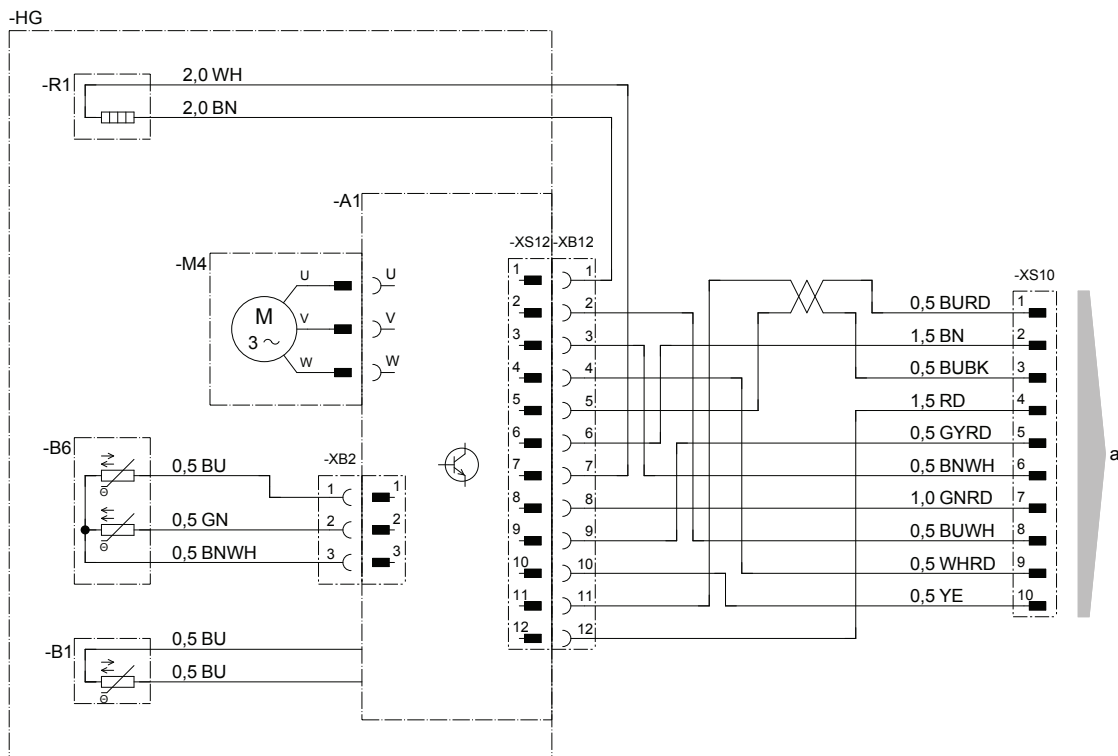
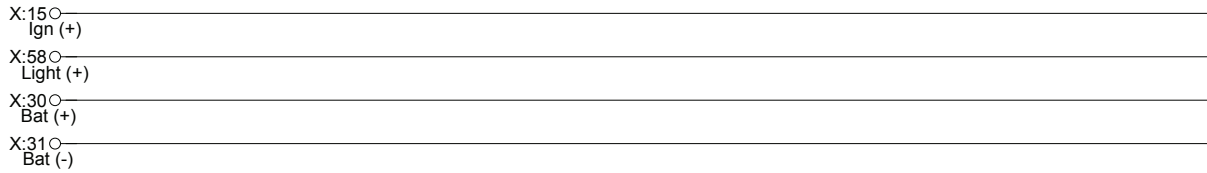

Parts list on Page 43

25.2720.00.9601.0A

6.3.2 Cable harness

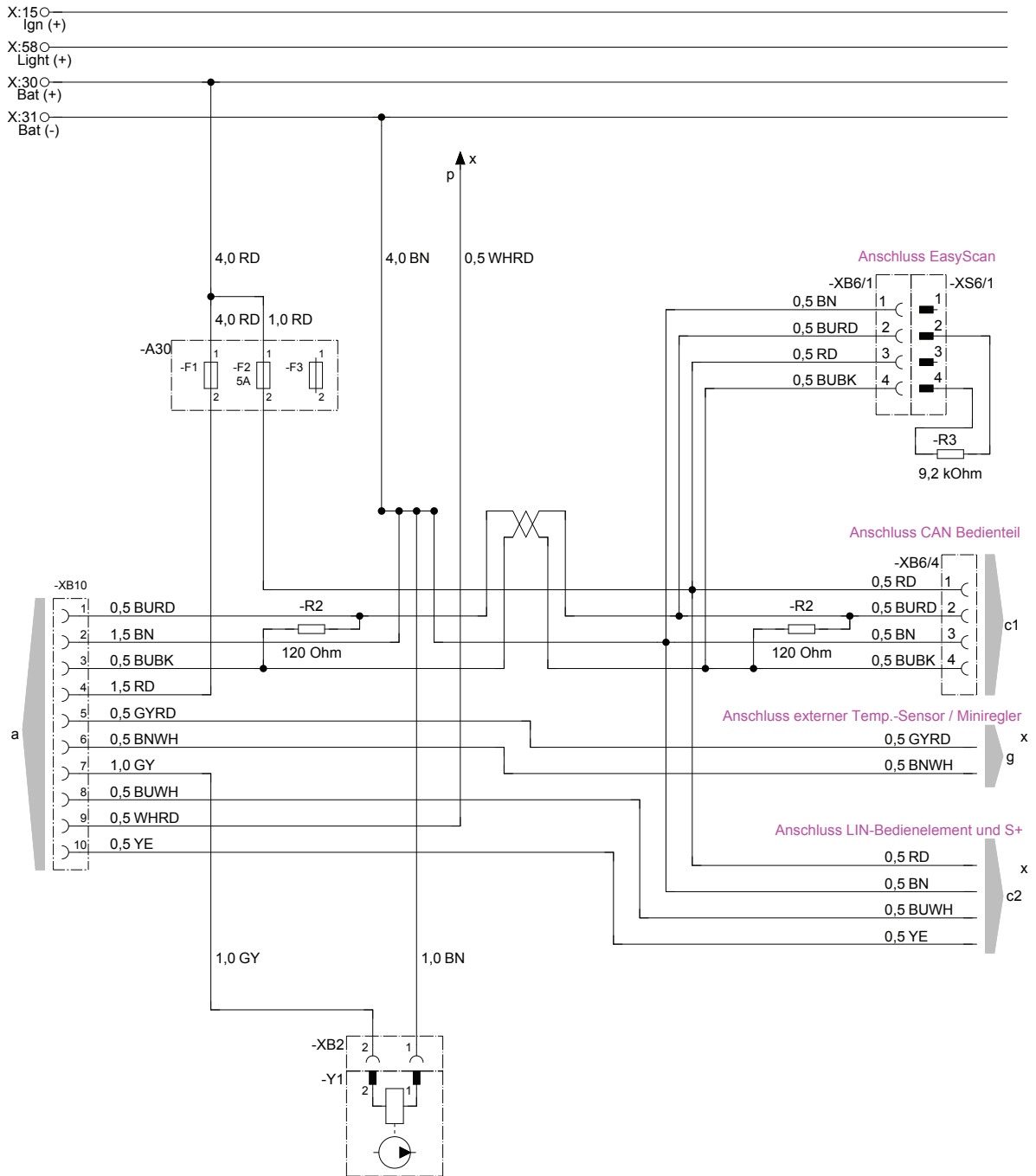

Parts list on Page 44

25.2720.00.9602.0A

6.3.3 Cable harness with ADR (24 V only)

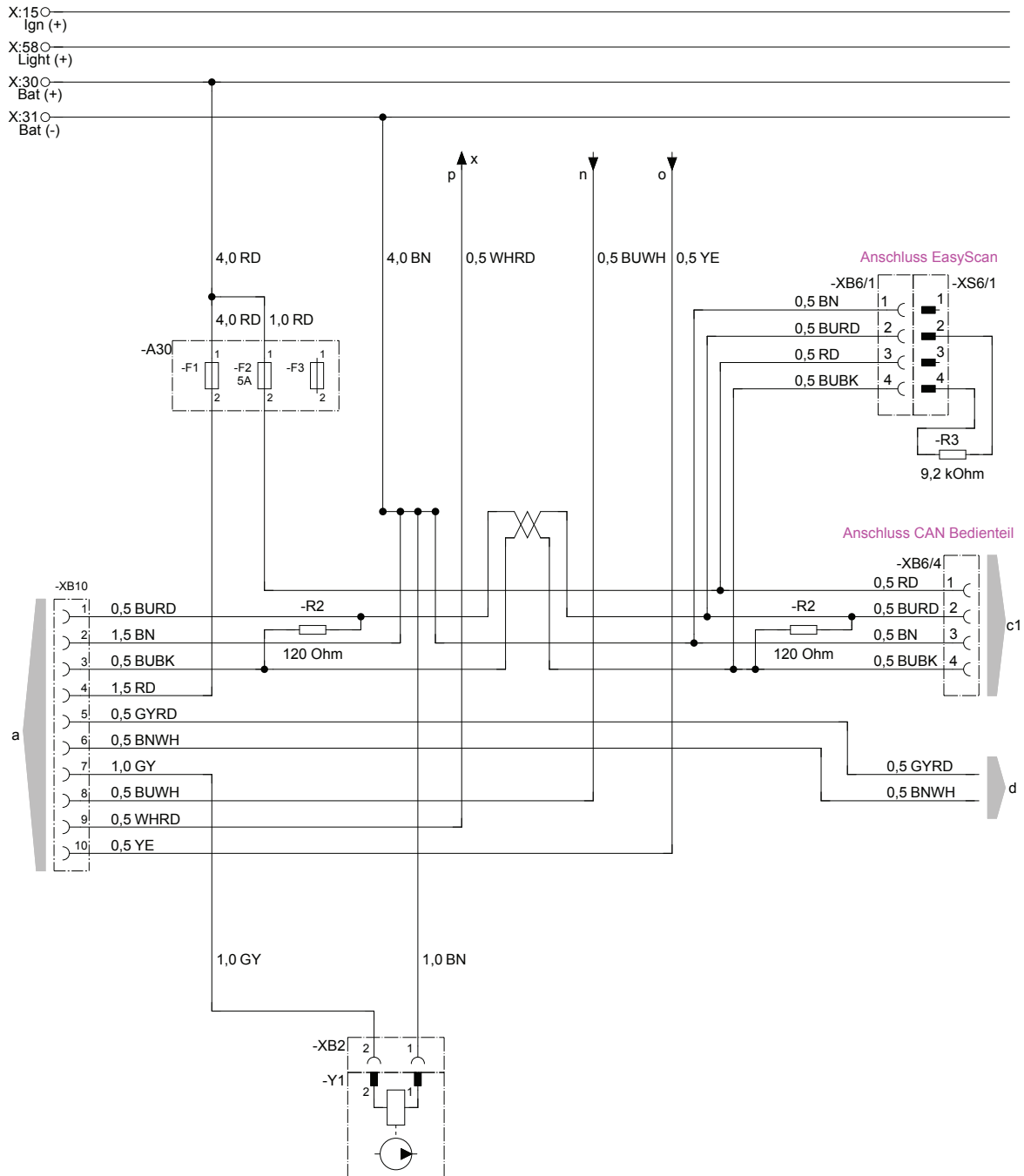

Parts list on Page 45

25.2720.00.9603.0A

6.4 Circuit diagrams, control units TP 7.0 (for 12 V only)

6.4.1 EasyStart Timer

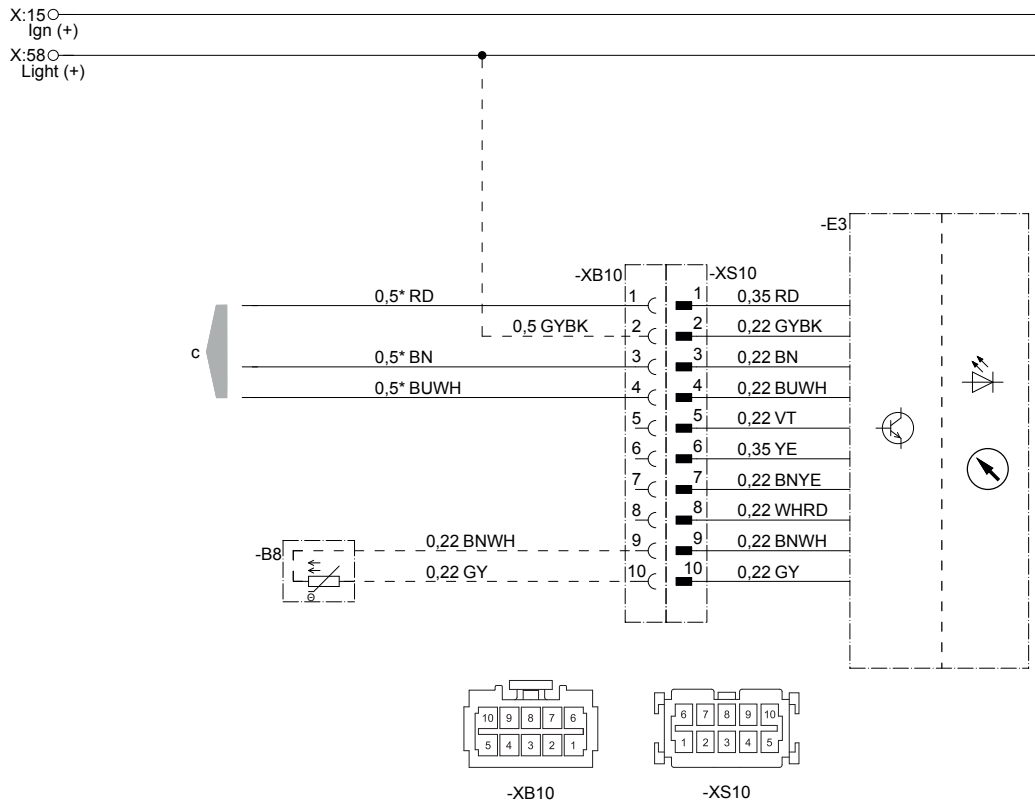

22.1000.34.9701

- B8 Room temperature sensor (optional)
- E3 EasyStart Timer
- c to the heater

i Note

- Heater circuit diagrams, from Page 46.
- Further circuit diagrams for the EasyStart timer are printed in the Installation Instructions Plus, these are available to view and download from the Service Portal.

6.4.2 EasyStart Remote+

X:15  Ign (+)
 X:58  Light (+)

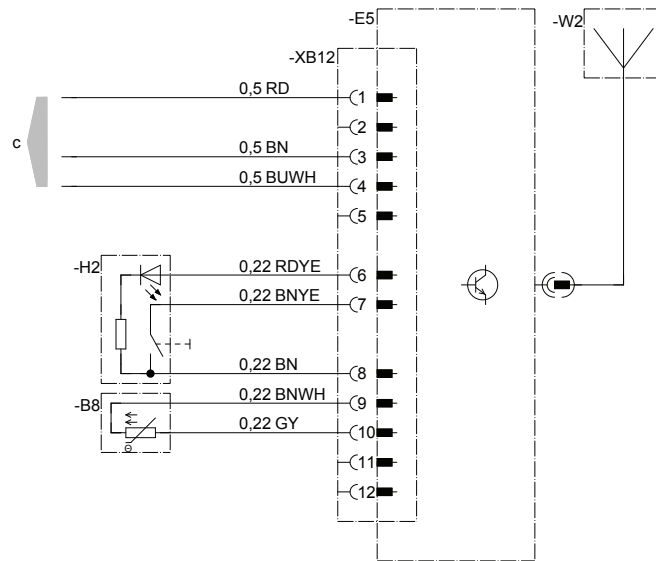

22.1000.34.9729

- B8 Room temperature sensor
- E5 Stationary unit, EasyStart Remote+
- H2 Button
- W2 Antenna
- c to the heater

i Note

- Heater circuit diagrams, from Page 47.
- Further circuit diagrams for the EasyStart Remote+ are printed in the Installation Instructions Plus, these are available to view and download from the Service Portal.

6.4.3 Easy Start Remote

X:15  Ign (+)

X:58  Light (+)

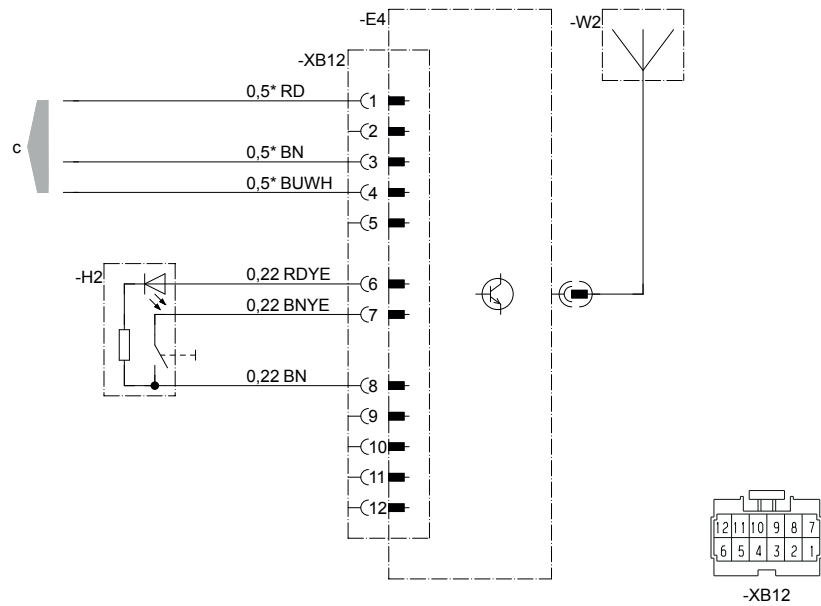

22.1000.34.9733

- E4 Stationary unit EasyStart Remote
- H2 Button
- W2 Antenna
- c to the heater

i Note

- Heater circuit diagrams, from Page 48.
- Further circuit diagrams for the EasyStart Remote are printed in the Installation Instructions Plus, these are available to view and download from the Service Portal.

6.4.4 EasyStart Select

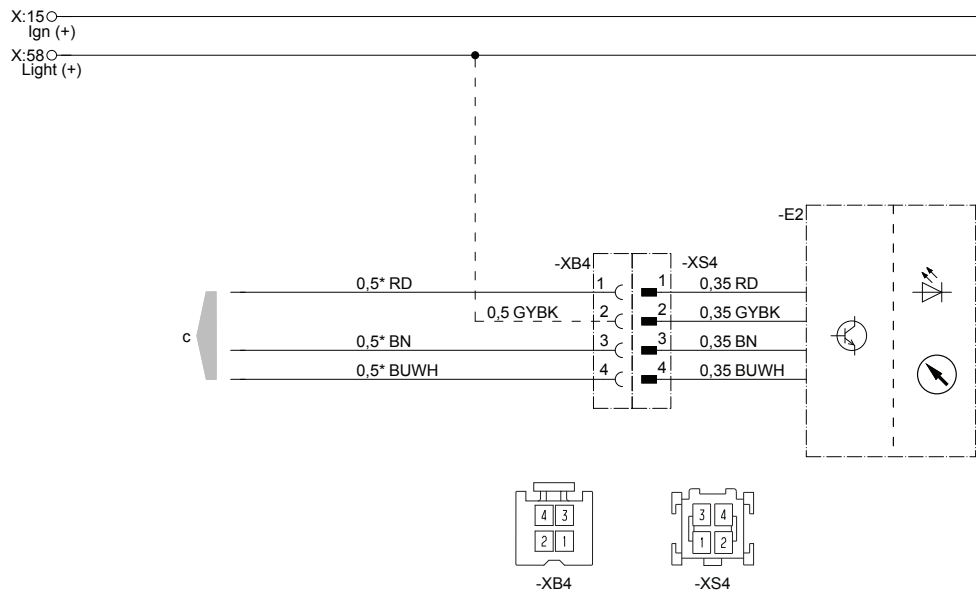

22.1000.34.9734

-E2 EasyStart Select
c to the heater

Note

- Heater circuit diagrams, from Page 49.
- Further circuit diagrams for the EasyStart Select are printed in the Installation Instructions Plus, these are available to view and download from the Service Portal.

6.4.5 EasyStart Web

X:150 Ign (+)
 X:580 Light (+)

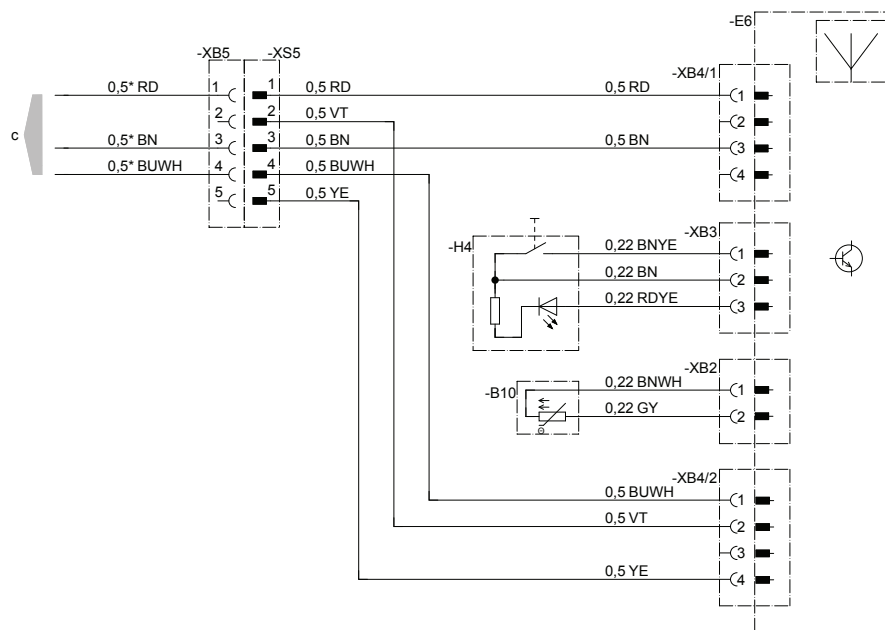

* Hydronic MII 0,75

22.1000.34.9719

- c to the heater
- H4 Easy Start Web button
- B10 Sensor, interior temperature
- E6 EasyStart Web

i Note

- Heater circuit diagrams, from Page 50.
- Further circuit diagrams for the Easy Start Web are printed in the Installation Instructions Plus; these are available to view and download from the Service Portal.

6.5 Circuit diagrams, control units TP 7.1

6.5.1 Easy Start Pro

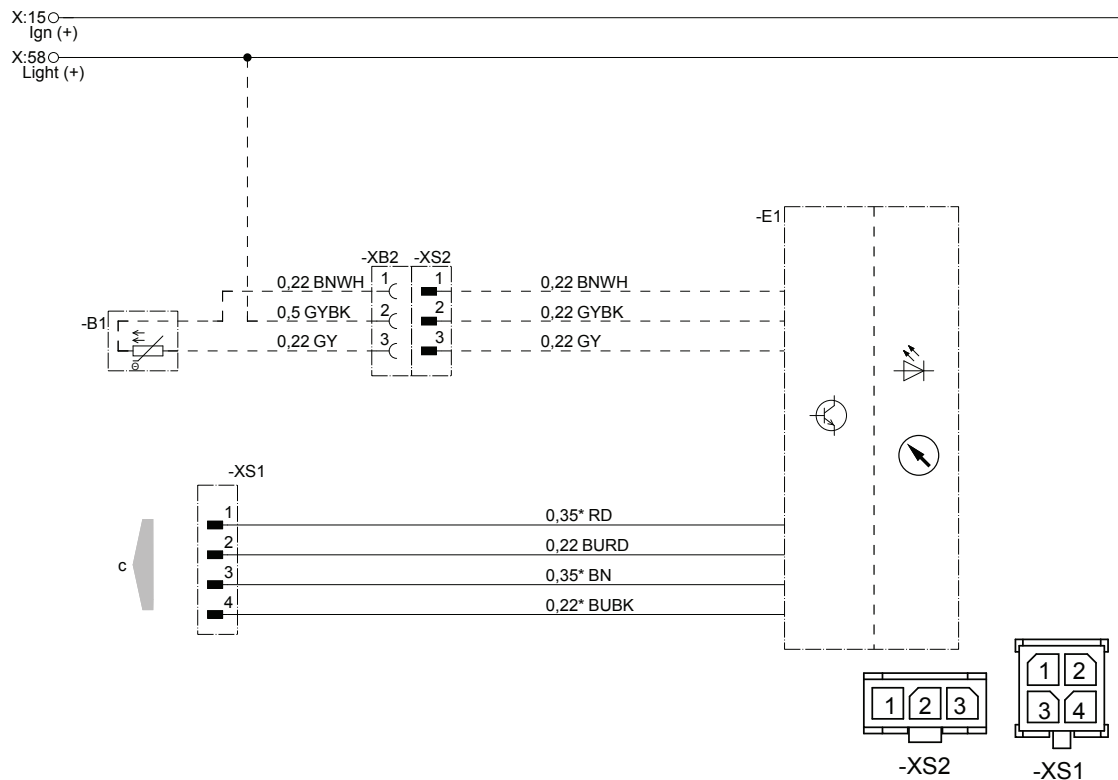

22.1000.35.2210

- B1 Room temperature sensor (optional)
- E1 Easy Start Pro
- c to the heater

i Note

- Heater circuit diagrams, from Page 51.
- Further circuit diagrams for the Easy Start Pro are printed in the Installation Instructions Plus; these are available to view and download from the Service Portal.

7 Service

7.1 Technical Support

If you have any technical questions or problems with the heater, the control unit or the operating software, please contact the following service address:
support-UK@eberspaecher.com

8 Environment

8.1 Certification

The high quality of the Eberspächer products is the key to our success.

To guarantee this quality, we have organised all work processes in the company along the lines of quality management (QM).

Even so, we still pursue a large number of activities for continuous improvement of product quality in order to keep pace with the similarly constantly growing requirements made by our customers.

All the steps necessary for quality assurance are stipulated in international standards.

This quality is to be considered in a total sense.

It concerns products, processes and customer - supplier relationships.

Officially approved public experts assess the system and the corresponding certification company awards a certificate.

Eberspächer Climate Control Systems GmbH & Co. KG has already qualified for the following standards:

**Quality management in accordance with
ISO TS 9001:2015 and IATF 16949:2016**

**Environmental management system in accordance with
ISO 14001:2015**

8.2 Disposal

Disposal of materials

End-of-life devices, defect components and packaging material can all be separated and sorted into pure-grade fractions so that all parts can be disposed of as required in an environment-friendly manner recycled where applicable.

Electric motors, control boxes and sensors (e.g. temperature sensors) are deemed to be "electronic scrap".

Dismantling the heater

The heater is dismantled according to the repair stages in the current troubleshooting / repair instructions.

Packaging

The packaging of the heater can be kept in case the heater has to be sent back.



www.krueger.co.uk

Eberspächer dealer



Eberspächer®

www.eberspaecher.com

All information in this manual is copyright of Eberspächer